

Plan

Ø74mm dia semi-spherical recess in gravitational centre of block for pin anchor. (pin anchor is rated to 2.5 tonnes with a safety factor of 3).

Total Block Weight : 800Kg.

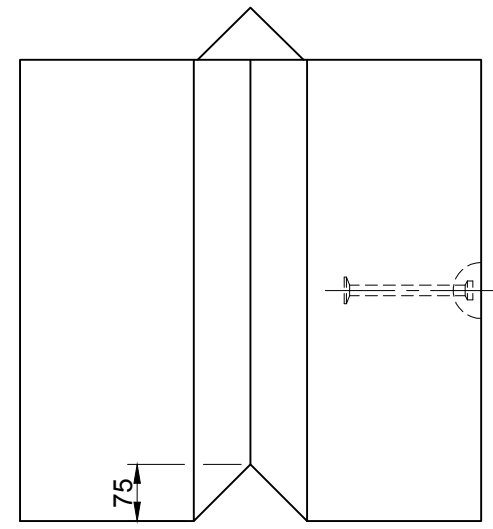

End

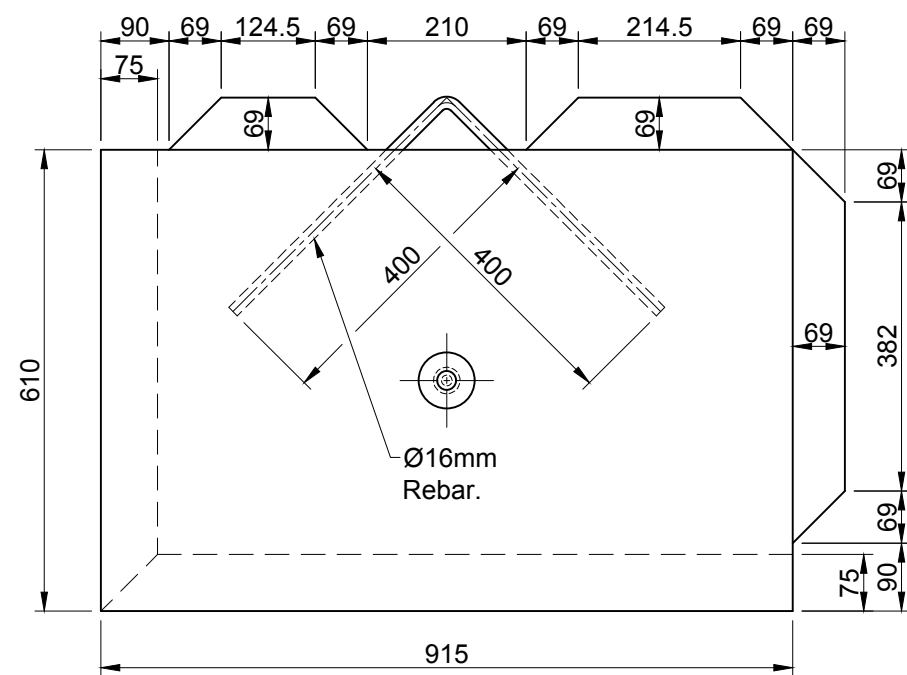

Elevation

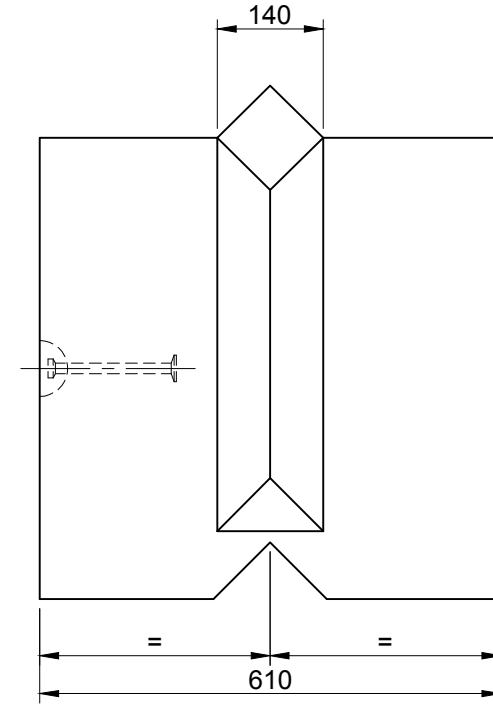

End

ALL Vee™ Interlocking Concrete Blocks are manufactured using high strength (50N/mm²) concrete and are Class A1 fire resistant in accordance with clause 4.3.4.4 of EN 13369.

										TITLE		Vee™ Interlocking Concrete Block 915 x 610 x 610 Elite Product Code : B1-915 also KV800		ELITE PRECAST CONCRETE LTD HALESFIELD 9, TELFORD SHROPSHIRE TF7 4QW											
REV	DATE	REASON FOR ISSUE	DRN	APP	REV	DATE	REASON FOR ISSUE	DRN	APP			DRN	CTC	CHKD	RMD	DATE	28-06-16	SIZE	A3	SCALE	1:10	DRG	EPC-VEE-004	REV	0
					0	28.06.16	For Information.			CTC	RMD														

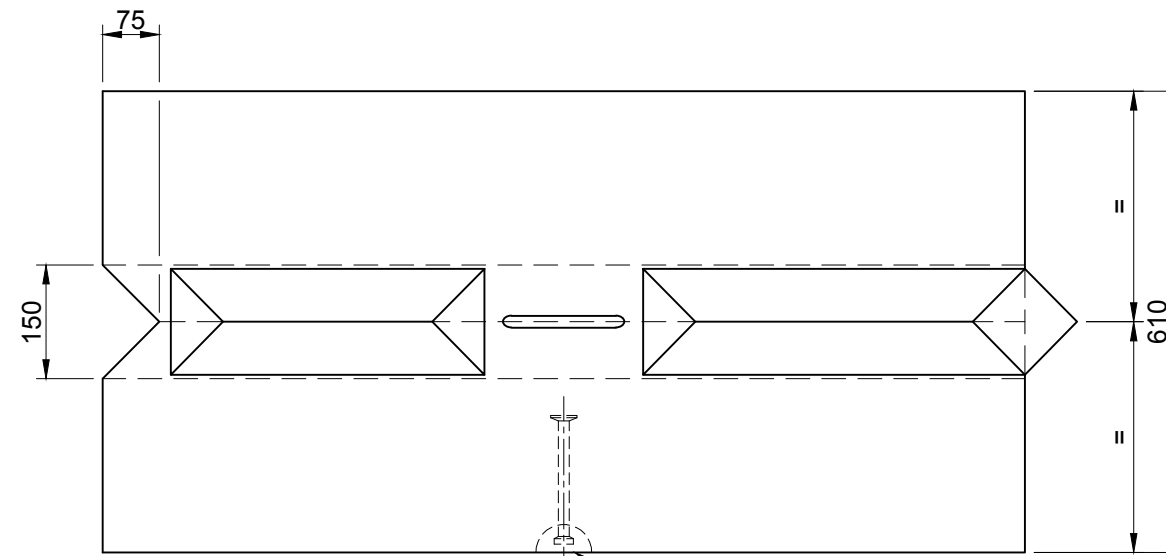

Plan

Ø74mm dia semi-spherical recess in gravitational centre of block for pin anchor. (pin anchor is rated to 2.5 tonnes with a safety factor of 3).

Total Block Weight : 1067Kg.

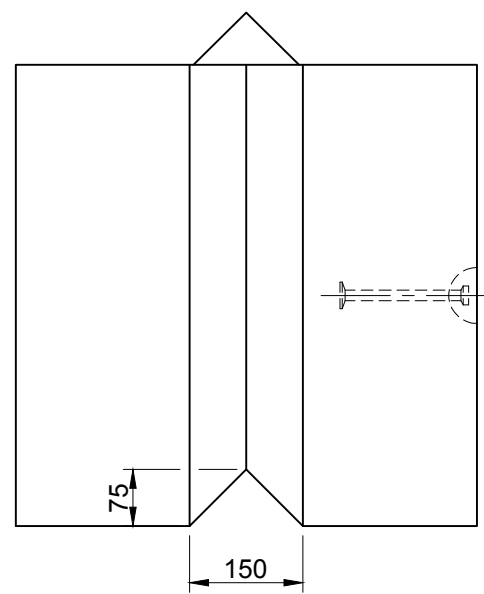

End

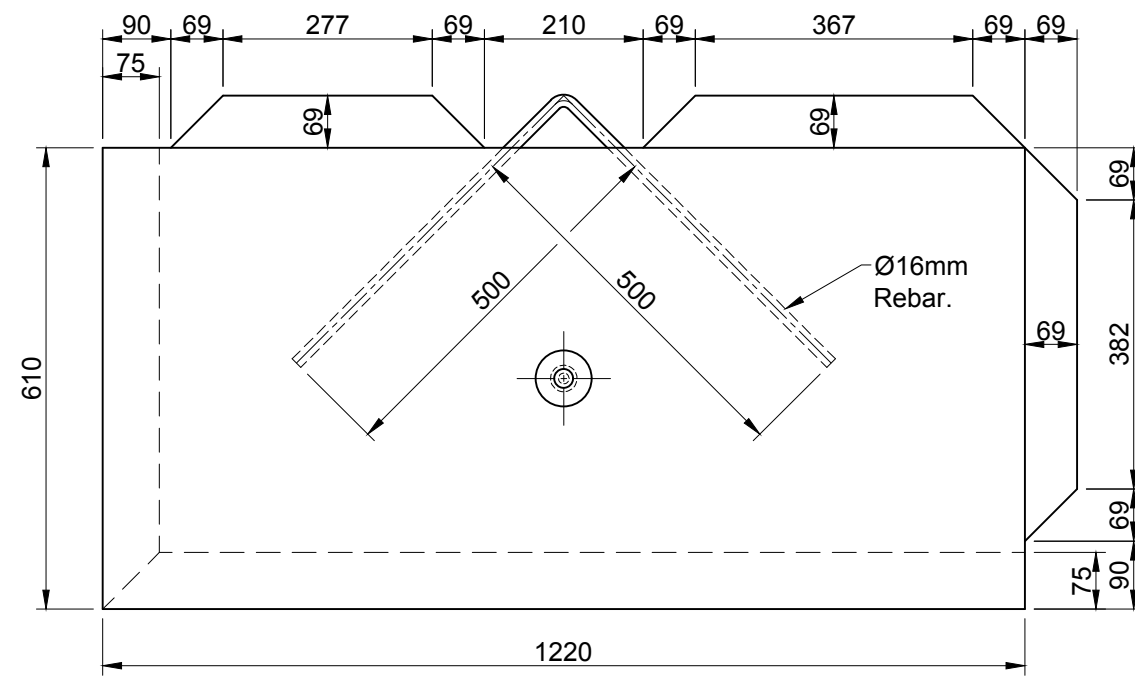

Elevation

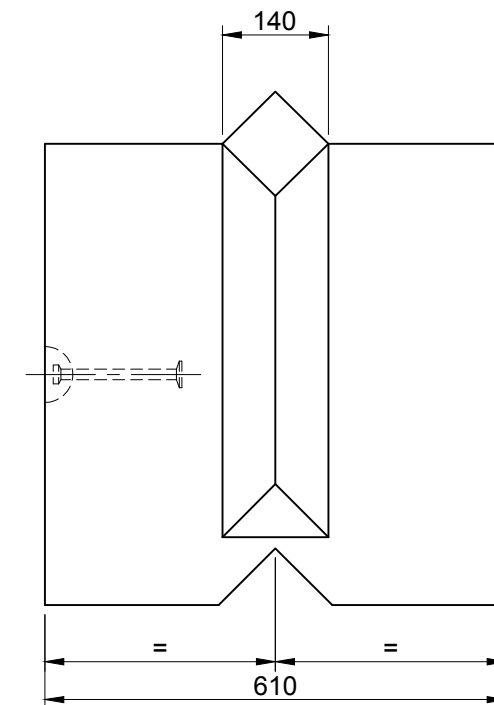

End

ALL Vee™ Interlocking Concrete Blocks are manufactured using high strength (50N/mm²) concrete and are Class A1 fire resistant in accordance with clause 4.3.4.4 of EN 13369.

										TITLE				ELITE PRECAST CONCRETE LTD HALESFIELD 9, TELFORD SHROPSHIRE TF7 4QW					
										Vee™ Interlocking Concrete Block 1220 x 610 x 610 Elite Product Code : B1-1220 also KV1067				SIZE A3 SCALE 1:10 DRG EPC-VEE-003 REV O					
REV	DATE	REASON FOR ISSUE	DRN	APP	REV	DATE	REASON FOR ISSUE	DRN	APP	CTC	RMD	DRN	CTC	CHKD	RMD	DATE	28-06-16		
					O	28.06.16	For Information.												

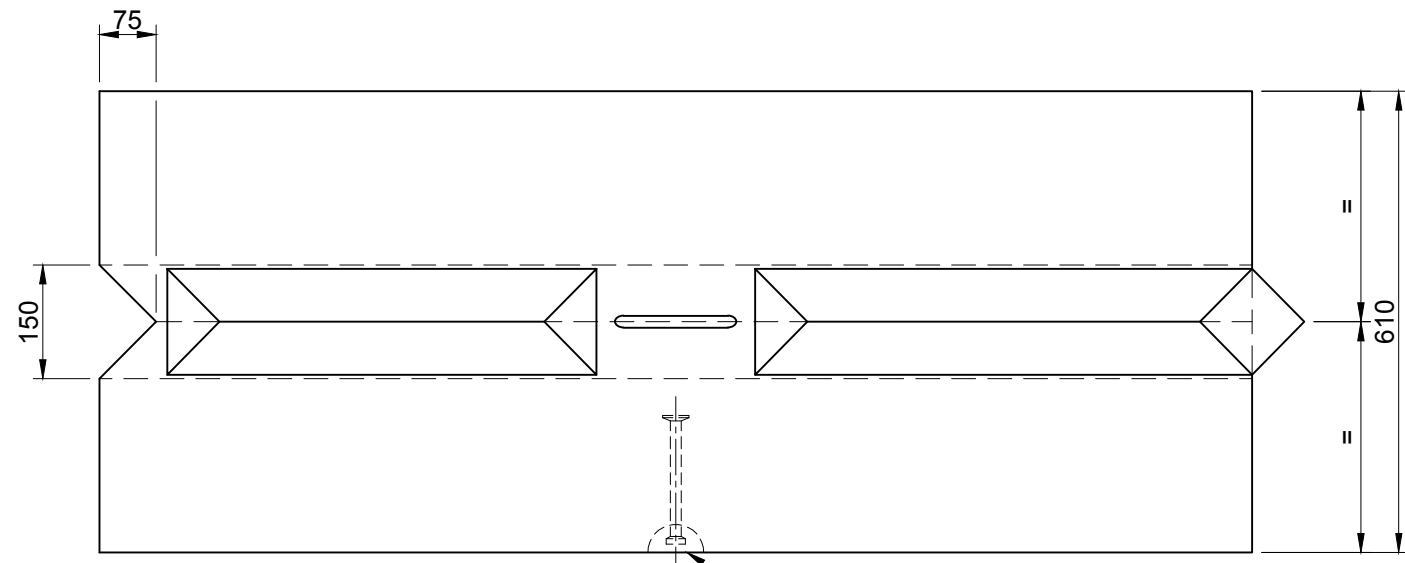

Plan
 Ø74mm dia semi-spherical recess in gravitational centre of block for pin anchor.
 (pin anchor is rated to 2.5 tonnes with a safety factor of 3).

Total Block Weight : 1333Kg.

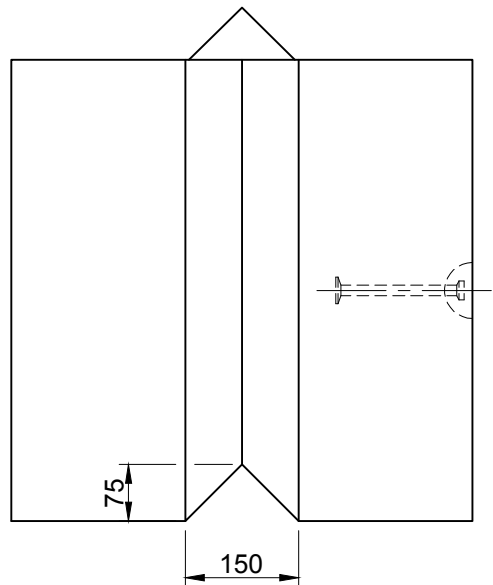

End

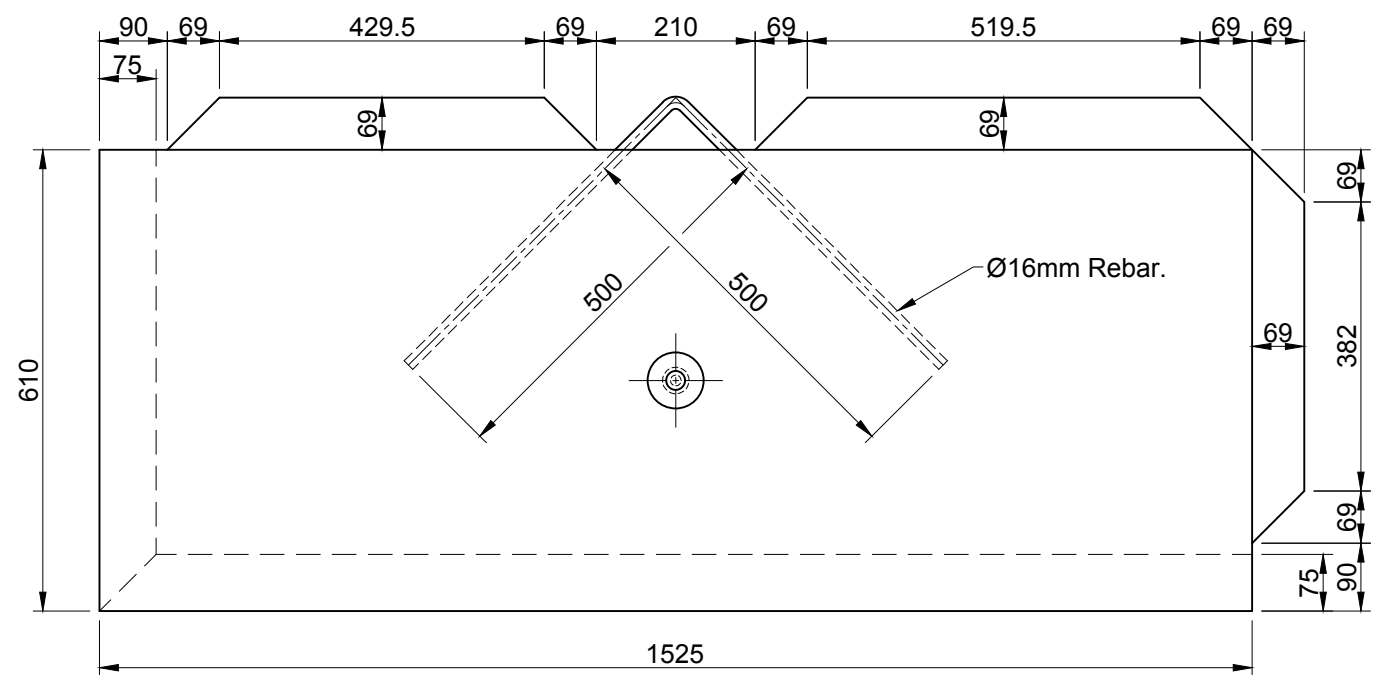

Elevation

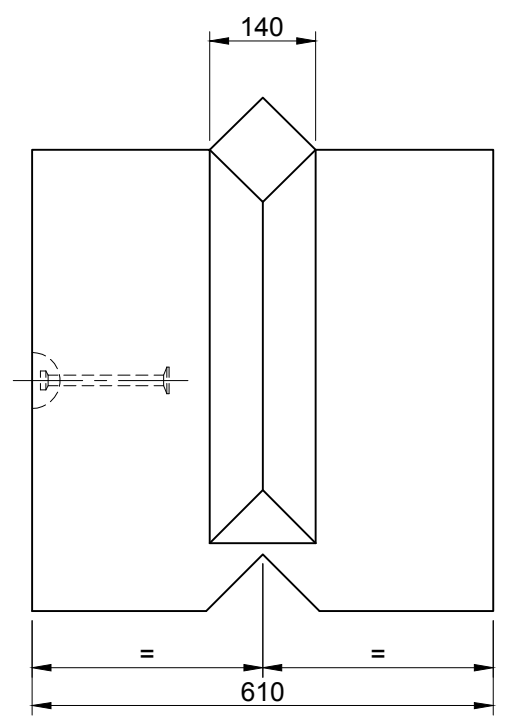

End

ALL Vee™ Interlocking Concrete Blocks are manufactured using high strength (50N/mm²) concrete and are Class A1 fire resistant in accordance with clause 4.3.4.4 of EN 13369.

										TITLE			ELITE PRECAST CONCRETE LTD HALESFIELD 9, TELFORD SHROPSHIRE TF7 4QW				
										Vee™ Interlocking Concrete Block 1525 x 610 x 610 Elite Product Code : B1-1525 also KV1333			SIZE A3 SCALE 1:10 DRG EPC-VEE-002				
REV	DATE	REASON FOR ISSUE	DRN	APP	REV	DATE	REASON FOR ISSUE	DRN	APP		CTC	CHKD	RMD	DATE	28-06-16	REV	O
					O	28.06.16	For Information.										

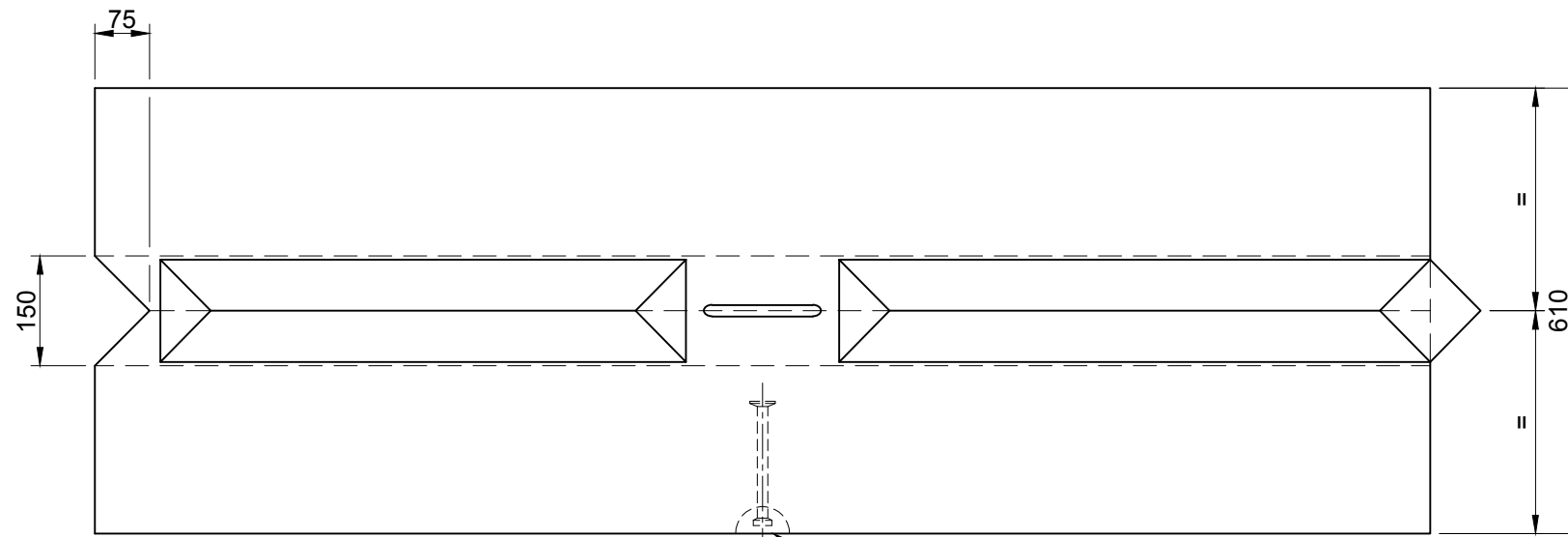

Plan

Ø74mm dia semi-spherical recess in gravitational centre of block for pin anchor. (pin anchor is rated to 2.5 tonnes with a safety factor of 3).

Total Block Weight : 1600Kg.

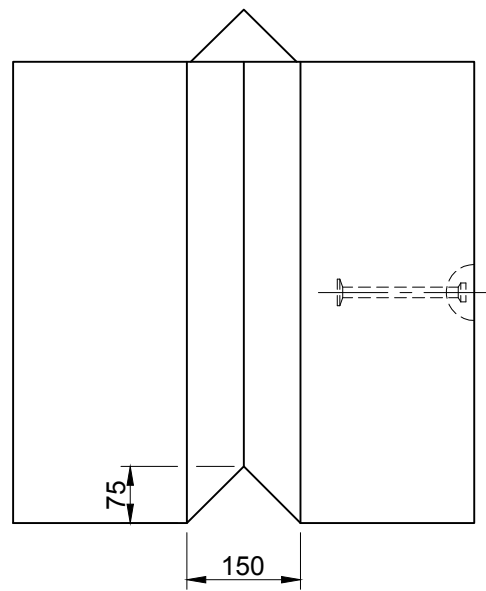

End

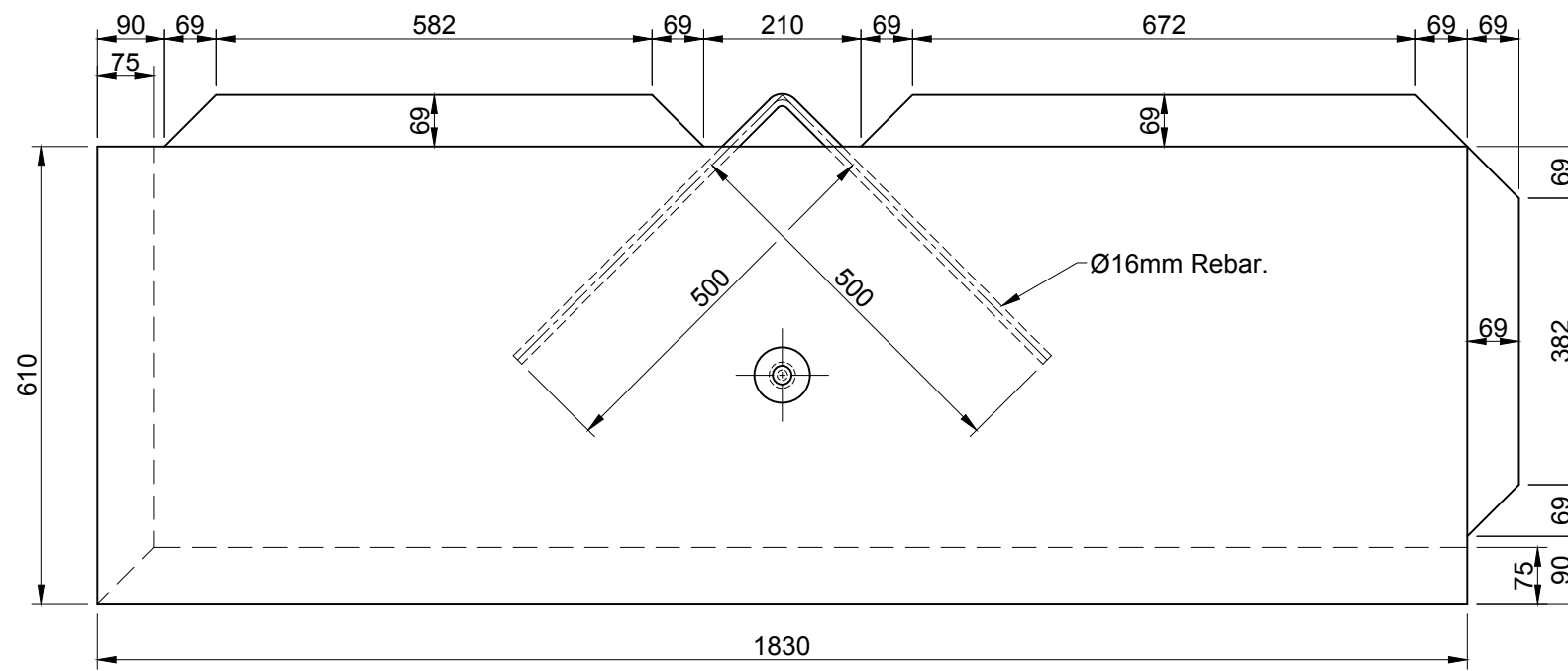

Elevation

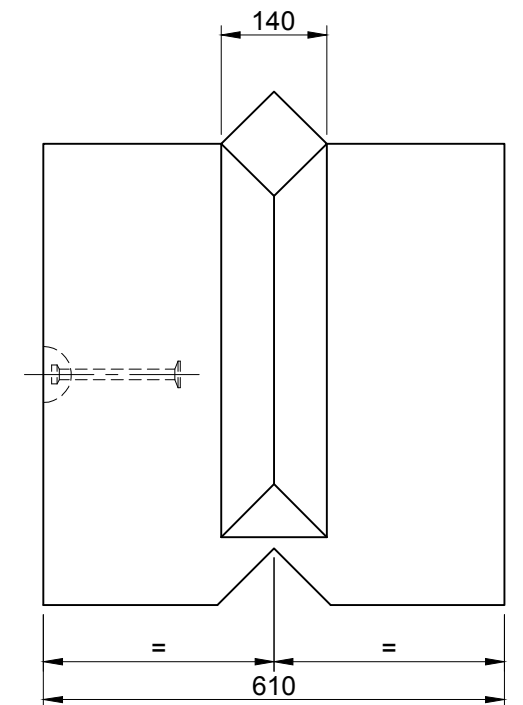

End

ALL Vee™ Interlocking Concrete Blocks are manufactured using high strength (50N/mm²) concrete and are Class A1 fire resistant in accordance with clause 4.3.4.4 of EN 13369.

										TITLE Vee™ Interlocking Concrete Block 1830 x 610 x 610mm Elite Product Code : B1-1830 also KV1600				ELITE PRECAST CONCRETE LTD HALESFIELD 9, TELFORD SHROPSHIRE TF7 4QW											
REV	DATE	REASON FOR ISSUE	DRN	APP	REV	DATE	REASON FOR ISSUE	DRN	APP			DRN	CTC	CHKD	RMD	DATE	28-06-16	SIZE	A3	SCALE	1:10	DRG	EPC-VEE-001	REV	0
					0	28.06.16	For Information.			CTC	RMD														

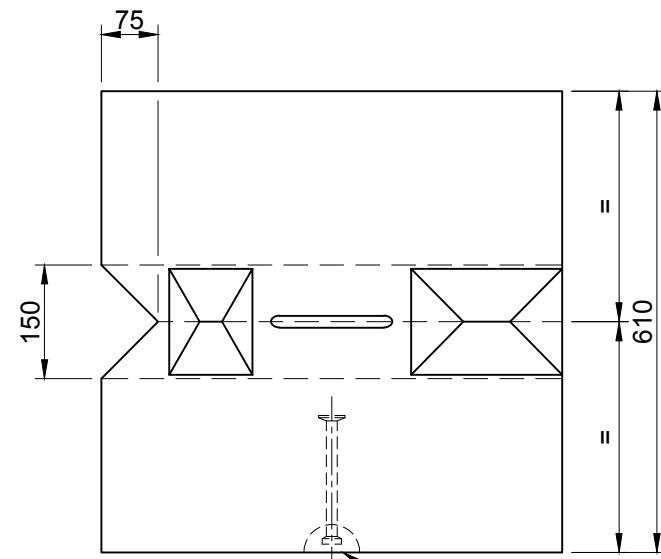

Plan

Ø74mm dia semi-spherical recess in gravitational centre of block for pin anchor. (pin anchor is rated to 2.5 tonnes with a safety factor of 3).

Total Block Weight : 533Kg.

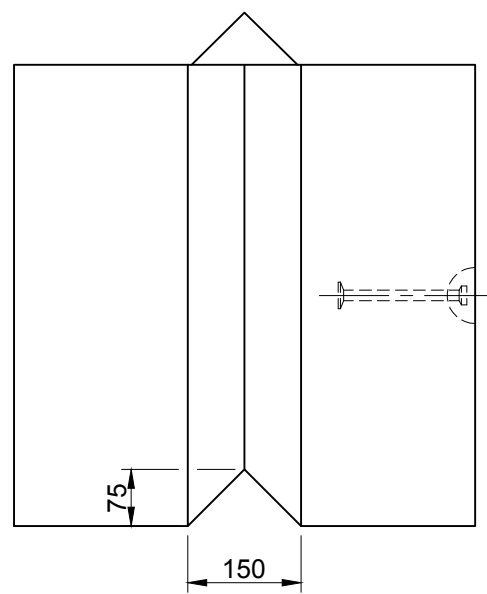

End

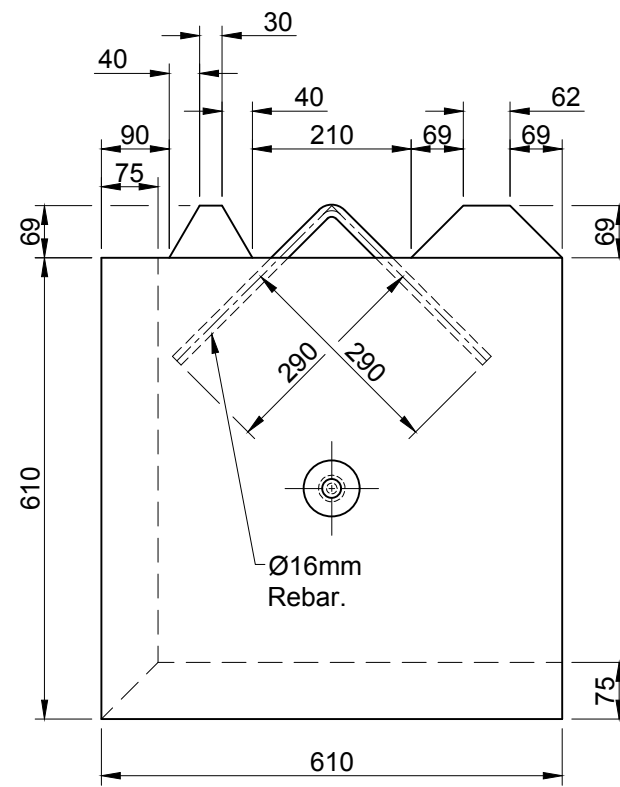

Elevation

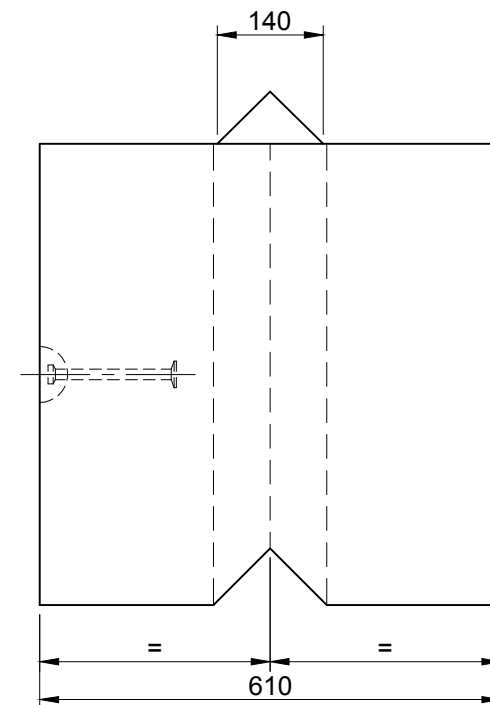

End

ALL Vee™ Interlocking Concrete Blocks are manufactured using high strength (50N/mm²) concrete and are Class A1 fire resistant in accordance with clause 4.3.4.4 of EN 13369.

										TITLE		Vee™ Interlocking Concrete Block B2 - 610 x 610 x 610 Elite Product Code : B2-610		ELITE PRECAST CONCRETE LTD HALESFIELD 9, TELFORD SHROPSHIRE TF7 4QW											
REV	DATE	REASON FOR ISSUE	DRN	APP	REV	DATE	REASON FOR ISSUE	DRN	APP	CTC	RMD	DRN	CTC	CHKD	RMD	DATE	28-06-16	SIZE	A3	SCALE	1:10	DRG	EPC-VEE-010	REV	0

PROJECTION

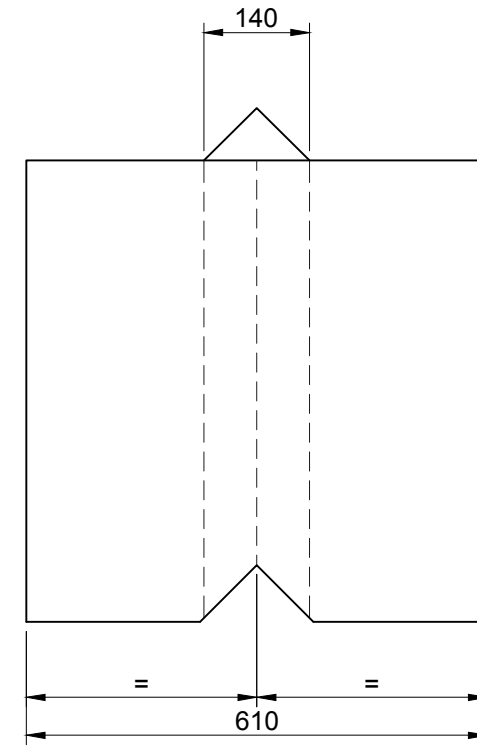
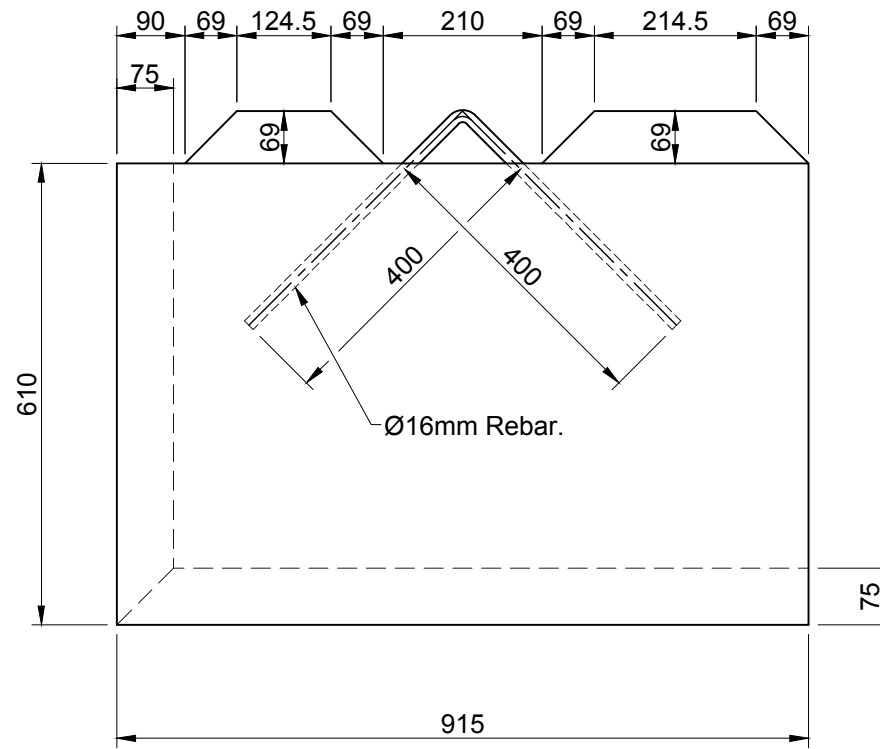
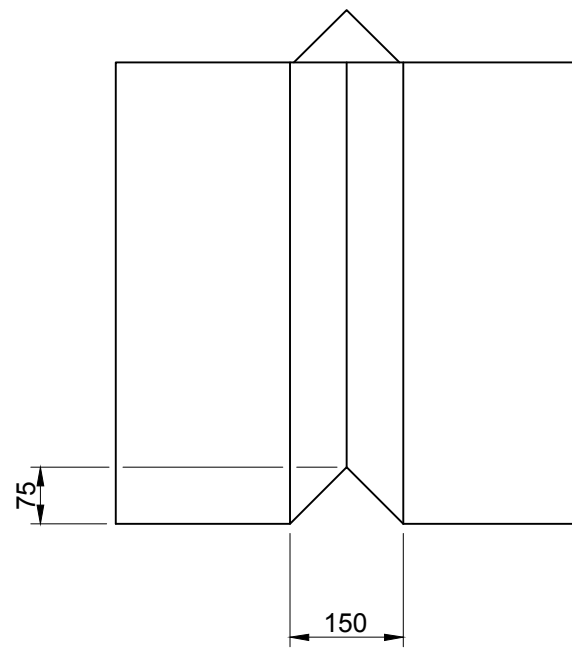
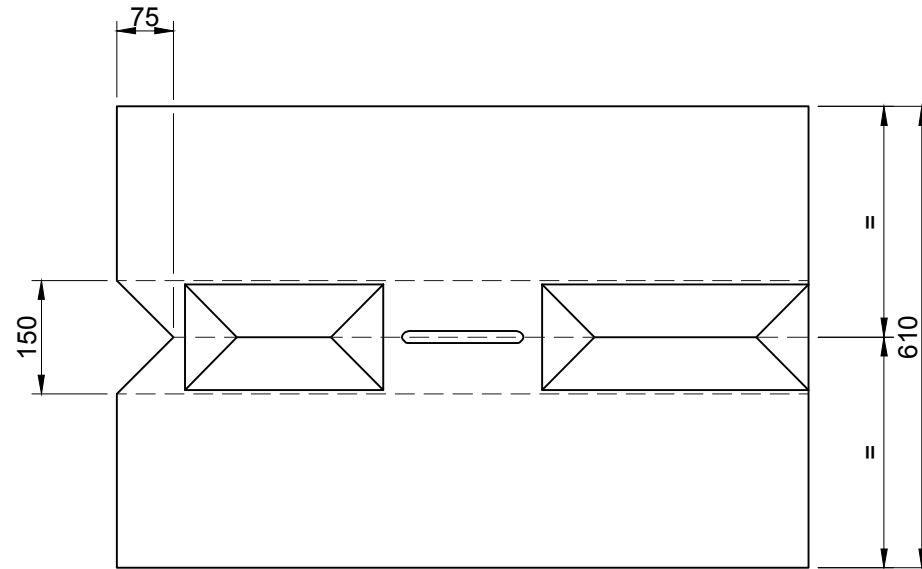

Weight : 800kg Approx.

					O	04.12.14	For Information			CTC	RD		
REV	DATE	REASON FOR ISSUE			DRN	APP	REV	DATE	REASON FOR ISSUE			DRN	APP
TITLE :					Vee™ Interlock Block B2 - 915 x 610 x 610 Elite Product Code : B2-915			ELITE PRECAST CONCRETE LIMITED HALESFIELD 9, TELFORD SHROPSHIRE TF7 4QW					
DRN :	CTC	CHKD :	RD	DATE :	04-12-14	DRG SIZE :	A3	SCALE :	1:10	DRG	171	REV	O

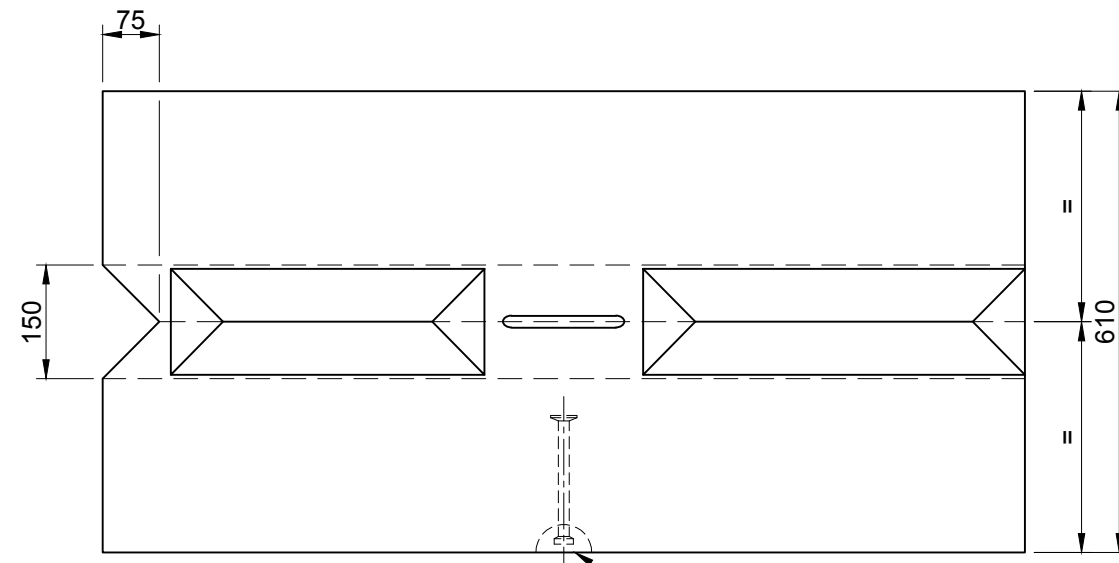

Plan
 Ø74mm dia semi-spherical recess in gravitational centre of block for pin anchor.
 (pin anchor is rated to 2.5 tonnes with a safety factor of 3).

Total Block Weight : 1067Kg.

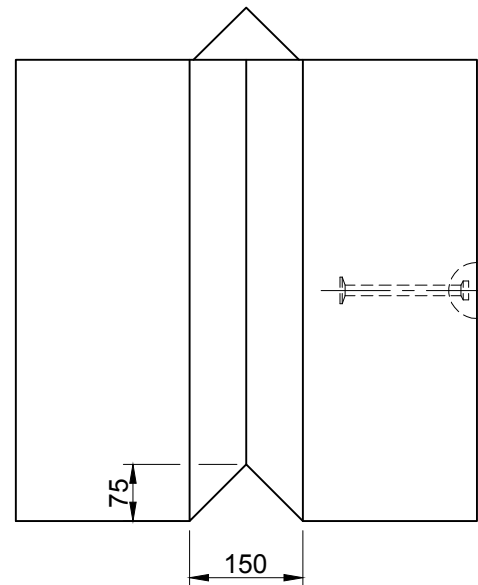

End

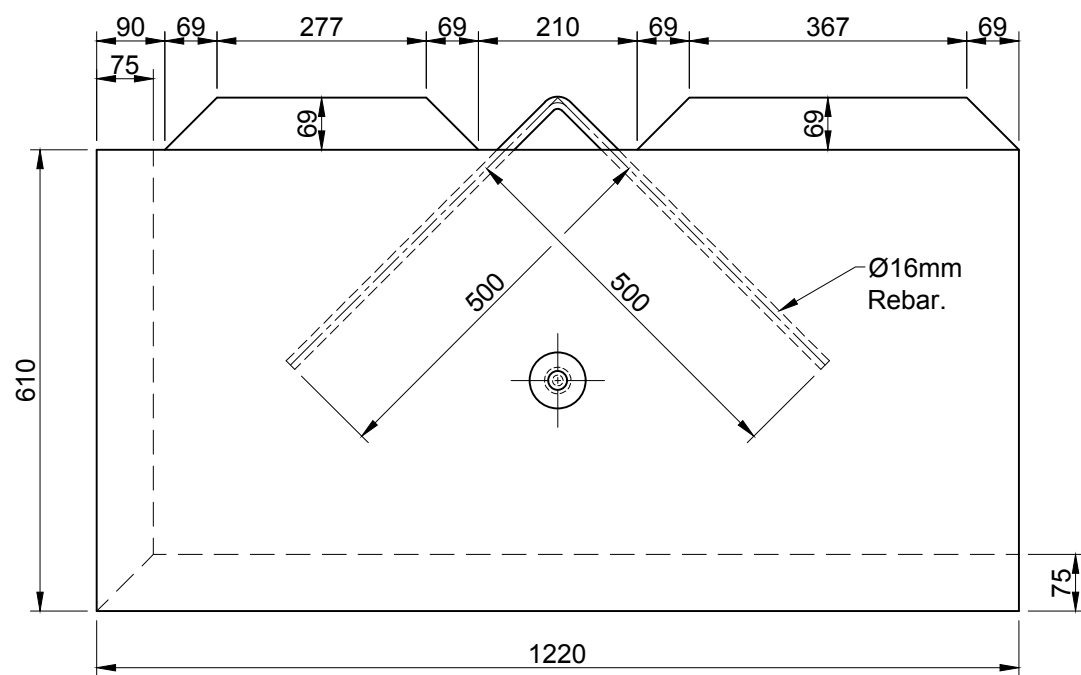

Elevation

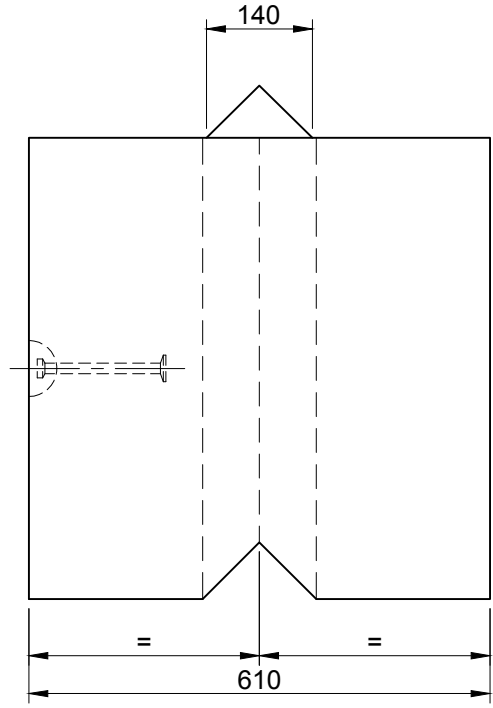

End

ALL Vee™ Interlocking Concrete Blocks are manufactured using high strength (50N/mm²) concrete and are Class A1 fire resistant in accordance with clause 4.3.4.4 of EN 13369.

										TITLE Vee™ Interlocking Concrete Block B2 - 1220 x 610 x 610 Elite Product Code : B2-1220				ELITE PRECAST CONCRETE LTD HALESFIELD 9, TELFORD SHROPSHIRE TF7 4QW											
REV	DATE	REASON FOR ISSUE	DRN	APP	REV	DATE	REASON FOR ISSUE	DRN	APP	CTC	RMD	DRN	CTC	CHKD	RMD	DATE	28-06-16	SIZE	A3	SCALE	1:10	DRG	EPC-VEE-008	REV	0

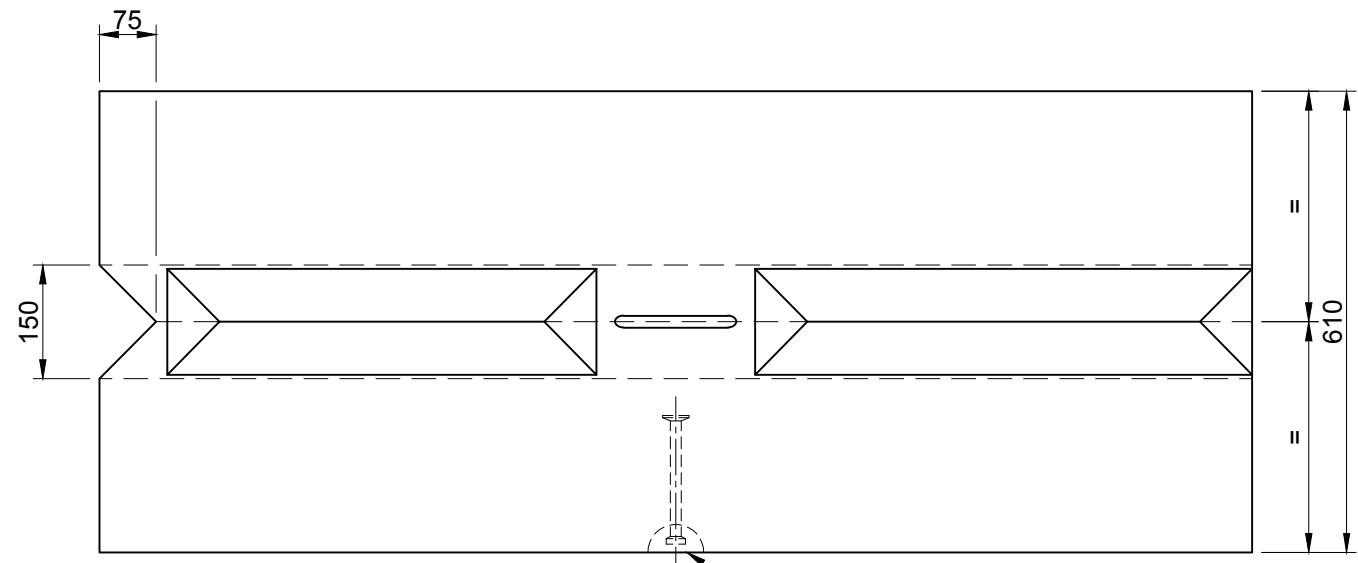

Plan
 Ø74mm dia semi-spherical recess in gravitational centre of block for pin anchor.
 (pin anchor is rated to 2.5 tonnes with a safety factor of 3).

Total Block Weight : 1333Kg.

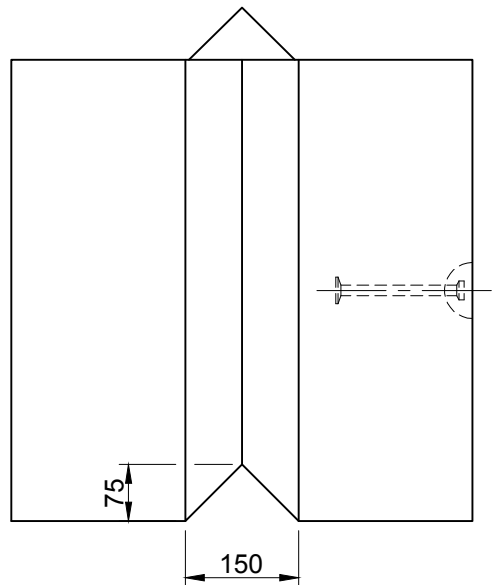

End

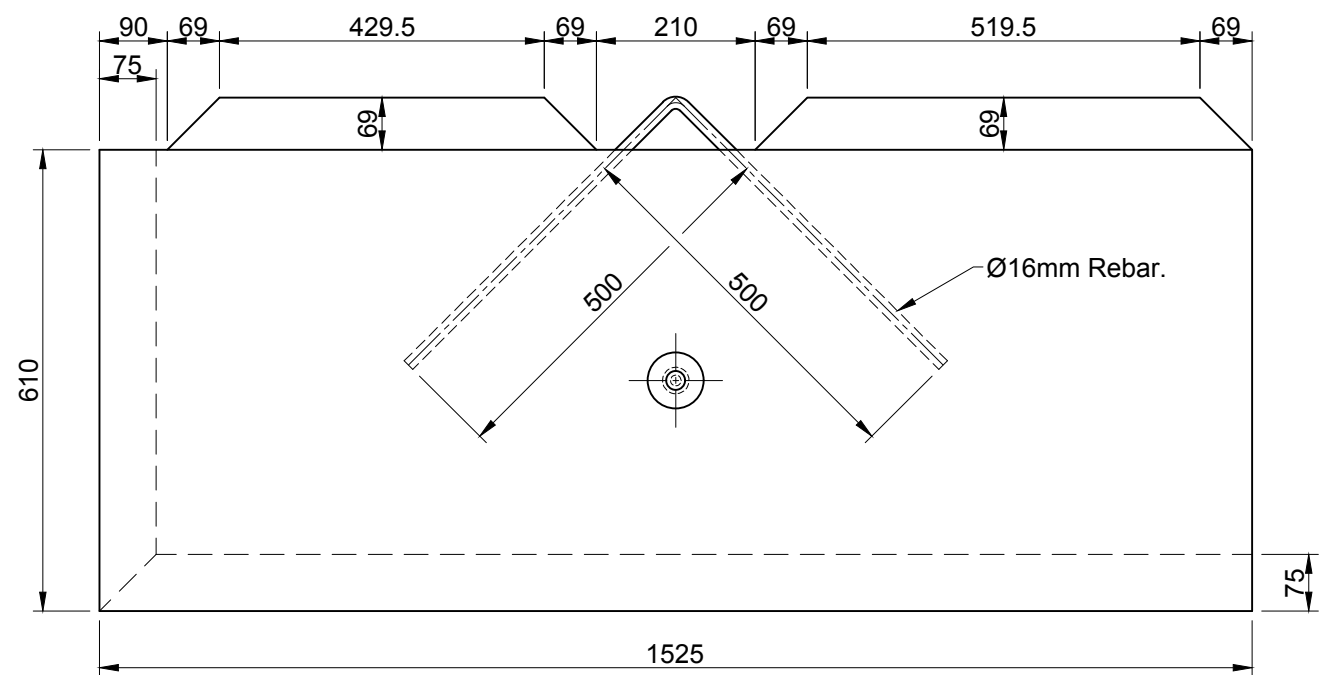

Elevation

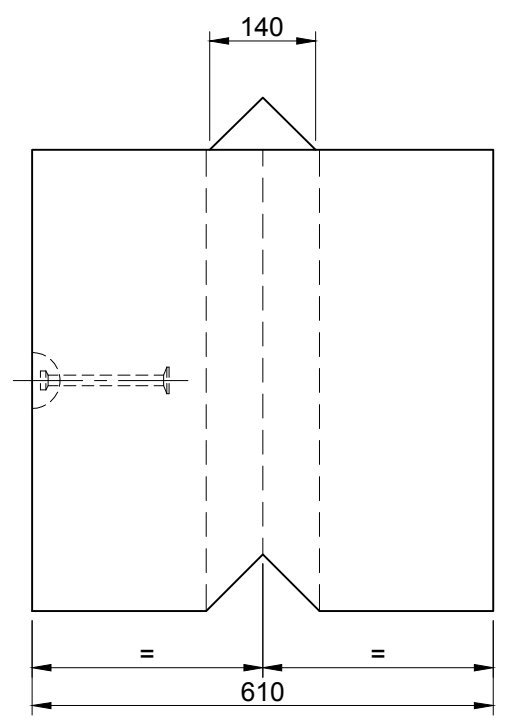

End

ALL Vee™ Interlocking Concrete Blocks are manufactured using high strength (50N/mm²) concrete and are Class A1 fire resistant in accordance with clause 4.3.4.4 of EN 13369.

										TITLE Vee™ Interlocking Concrete Block B2 - 1525 x 610 x 610 Elite Product Code : B2-1525				ELITE PRECAST CONCRETE LTD HALESFIELD 9, TELFORD SHROPSHIRE TF7 4QW											
REV	DATE	REASON FOR ISSUE	DRN	APP	REV	DATE	REASON FOR ISSUE	DRN	APP			DRN	CTC	CHKD	RMD	DATE	28-06-16	SIZE	A3	SCALE	1:10	DRG	EPC-VEE-007	REV	O
					O	28.06.16	For Information.																		

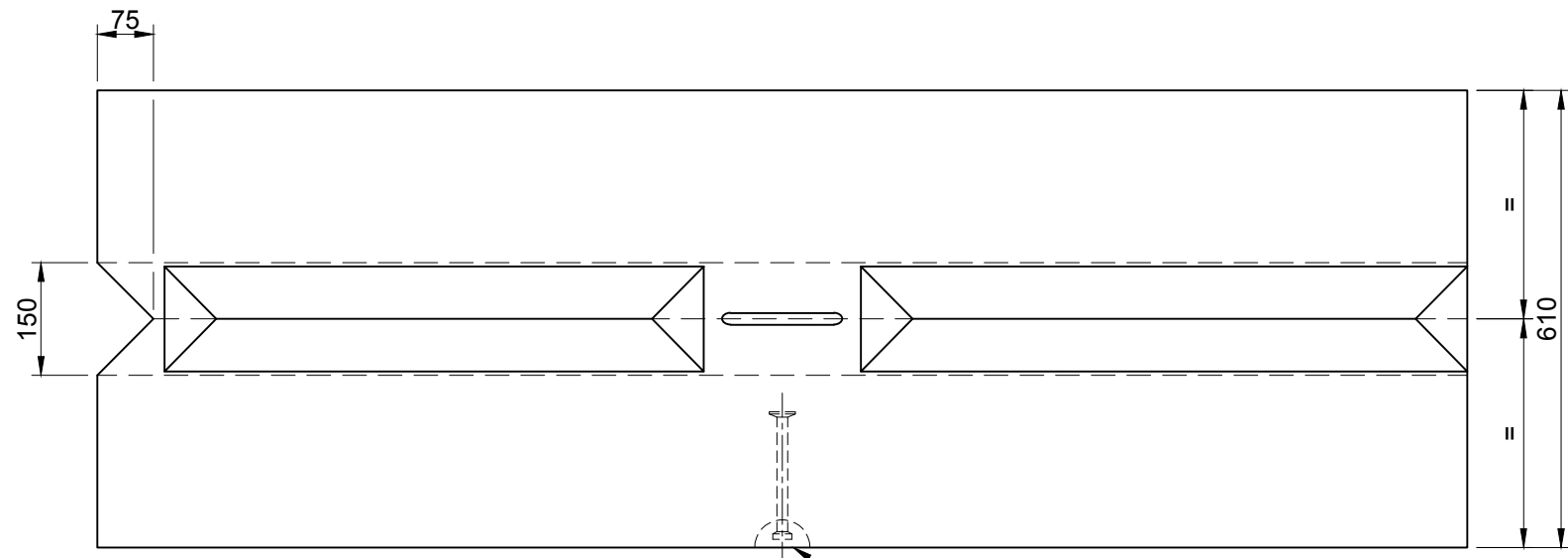

Total Block Weight : 1600Kg.

Plan
 Ø74mm dia semi-spherical recess in gravitational centre of block for pin anchor.
 (pin anchor is rated to 2.5 tonnes with a safety factor of 3).

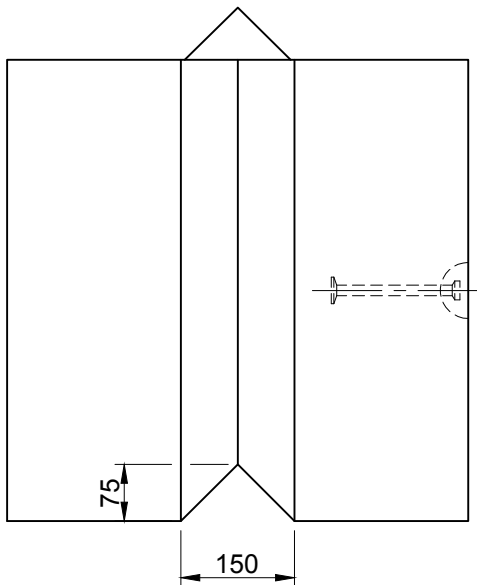

End

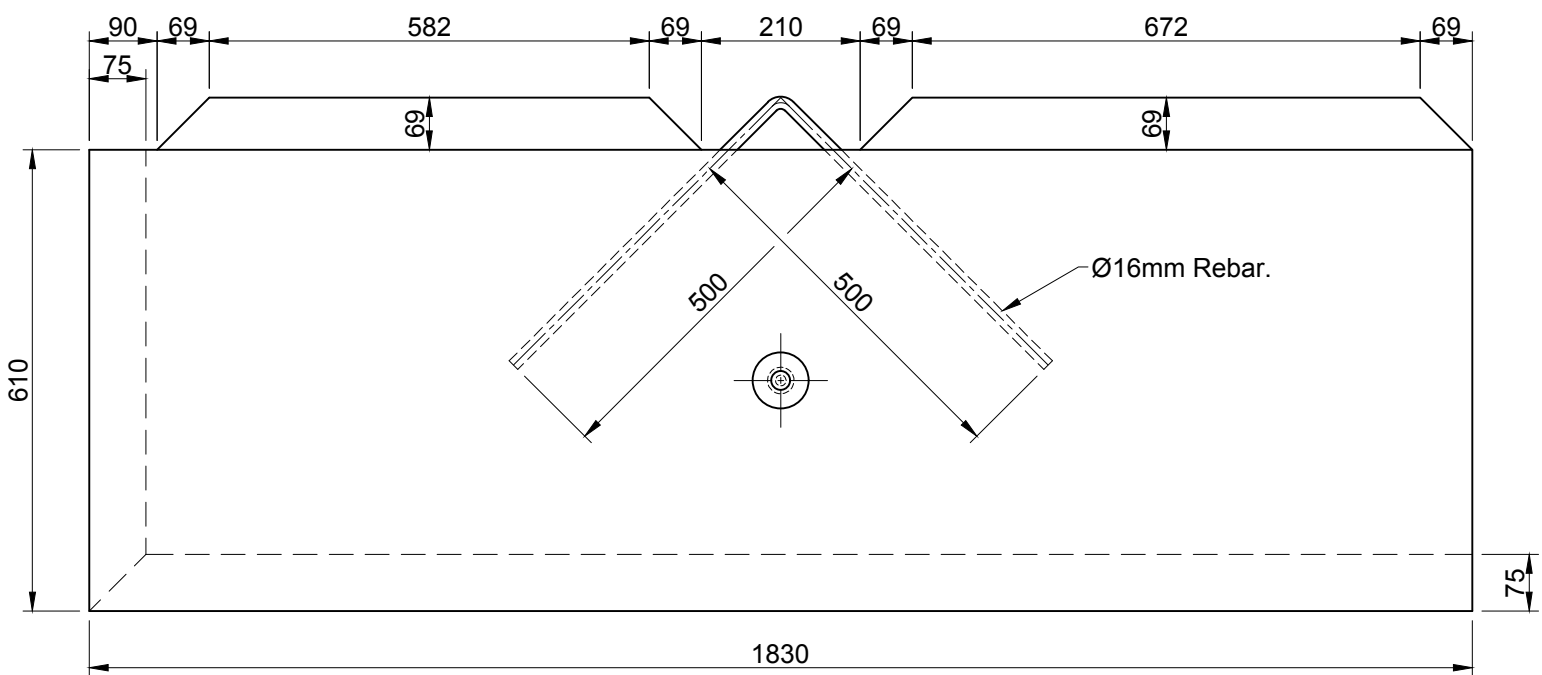

Elevation

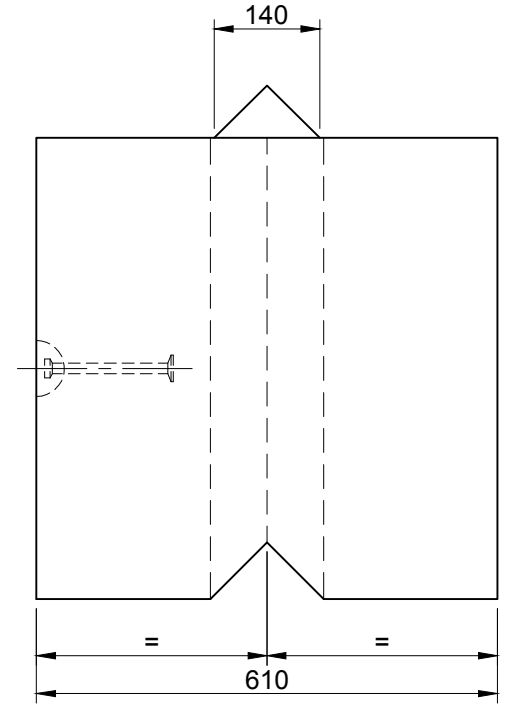

End

ALL Vee™ Interlocking Concrete Blocks are manufactured using high strength (50N/mm²) concrete and are Class A1 fire resistant in accordance with clause 4.3.4.4 of EN 13369.

										TITLE		Vee™ Interlocking Concrete Block		ELITE PRECAST CONCRETE LTD											
												B2 - 1830 x 610 x 610		HALESFIELD 9, TELFORD											
												Elite Product Code : B2-1830		SHROPSHIRE TF7 4QW											
REV	DATE	REASON FOR ISSUE	DRN	APP	REV	DATE	REASON FOR ISSUE	DRN	APP			DRN	CTC	CHKD	RMD	DATE	28-06-16	SIZE	A3	SCALE	1:10	DRG	EPC-VEE-006	REV	O

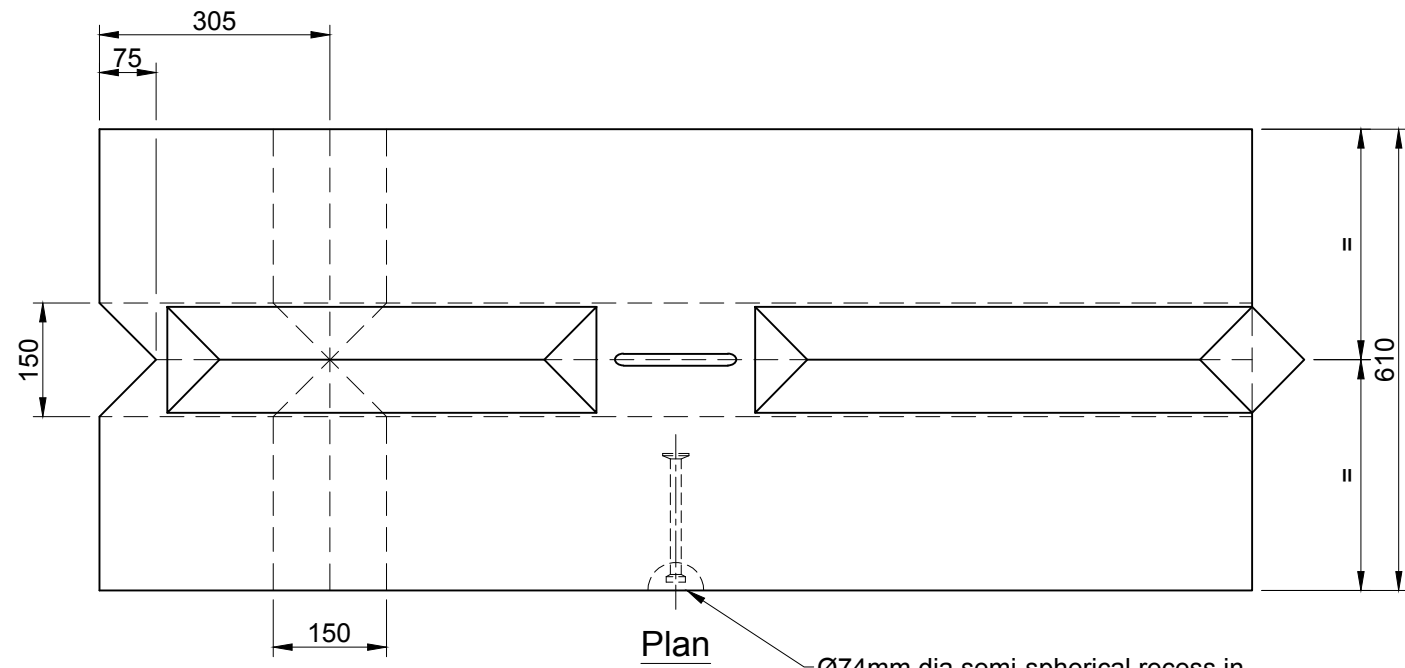

Total Block Weight : 1333Kg.

Plan
 Ø74mm dia semi-spherical recess in gravitational centre of block for pin anchor. (pin anchor is rated to 2.5 tonnes with a safety factor of 3).

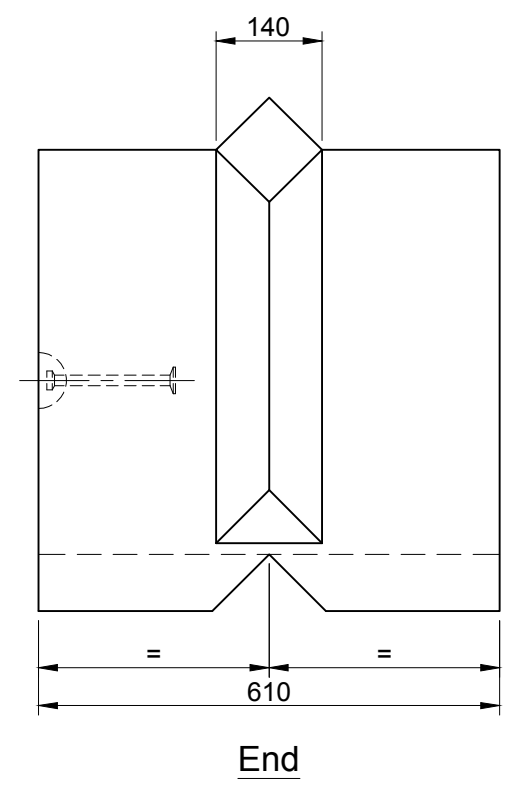
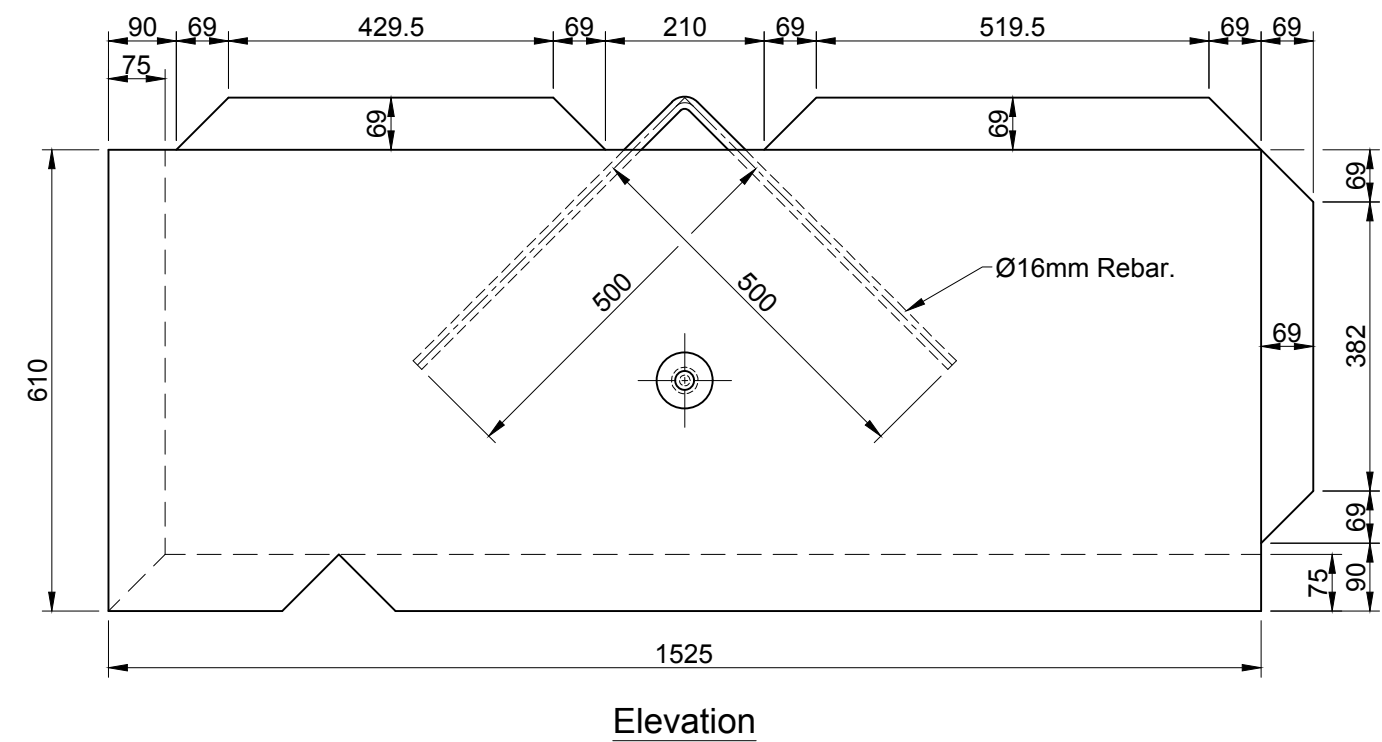
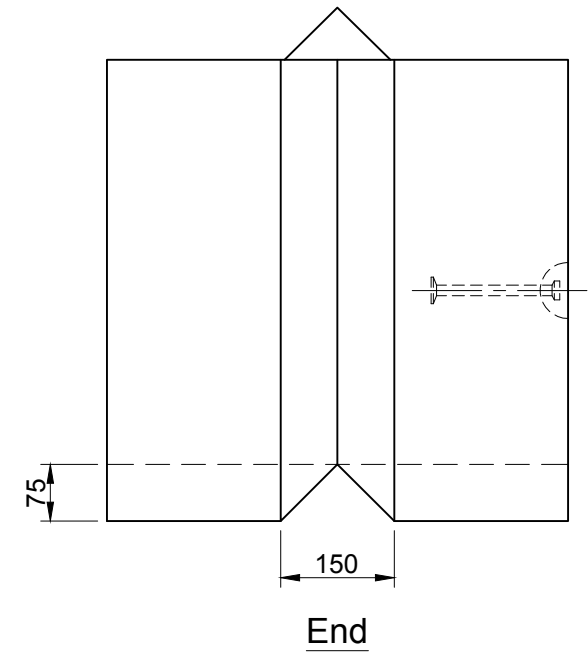

ALL Vee™ Interlocking Concrete Blocks are manufactured using high strength (50N/mm²) concrete and are Class A1 fire resistant in accordance with clause 4.3.4.4 of EN 13369.

										TITLE Vee™ Interlocking Concrete Block C1 - 1525 x 610 x 610 Elite Product Code : C1-1525				ELITE PRECAST CONCRETE LTD HALESFIELD 9, TELFORD SHROPSHIRE TF7 4QW											
REV	DATE	REASON FOR ISSUE	DRN	APP	REV	DATE	REASON FOR ISSUE	DRN	APP			DRN	CTC	CHKD	RMD	DATE	28-06-16	SIZE	A3	SCALE	1:10	DRG	EPC-VEE-021	REV	O
					O	28.06.16	For Information.			CTC	RMD														

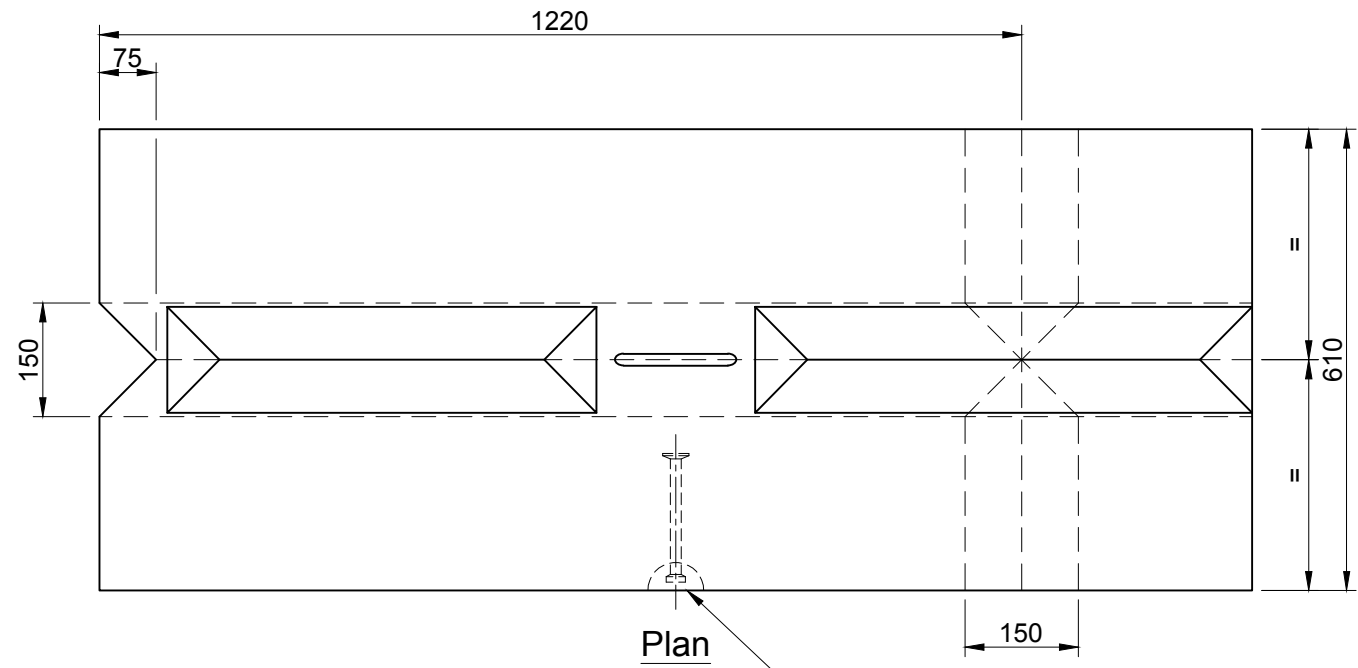

Total Block Weight : 1333Kg.

Ø74mm dia semi-spherical recess in gravitational centre of block for pin anchor. (pin anchor is rated to 2.5 tonnes with a safety factor of 3).

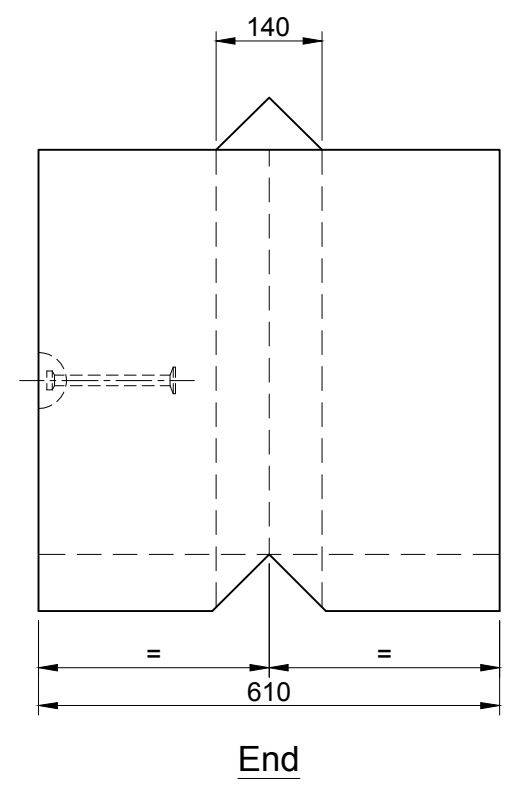
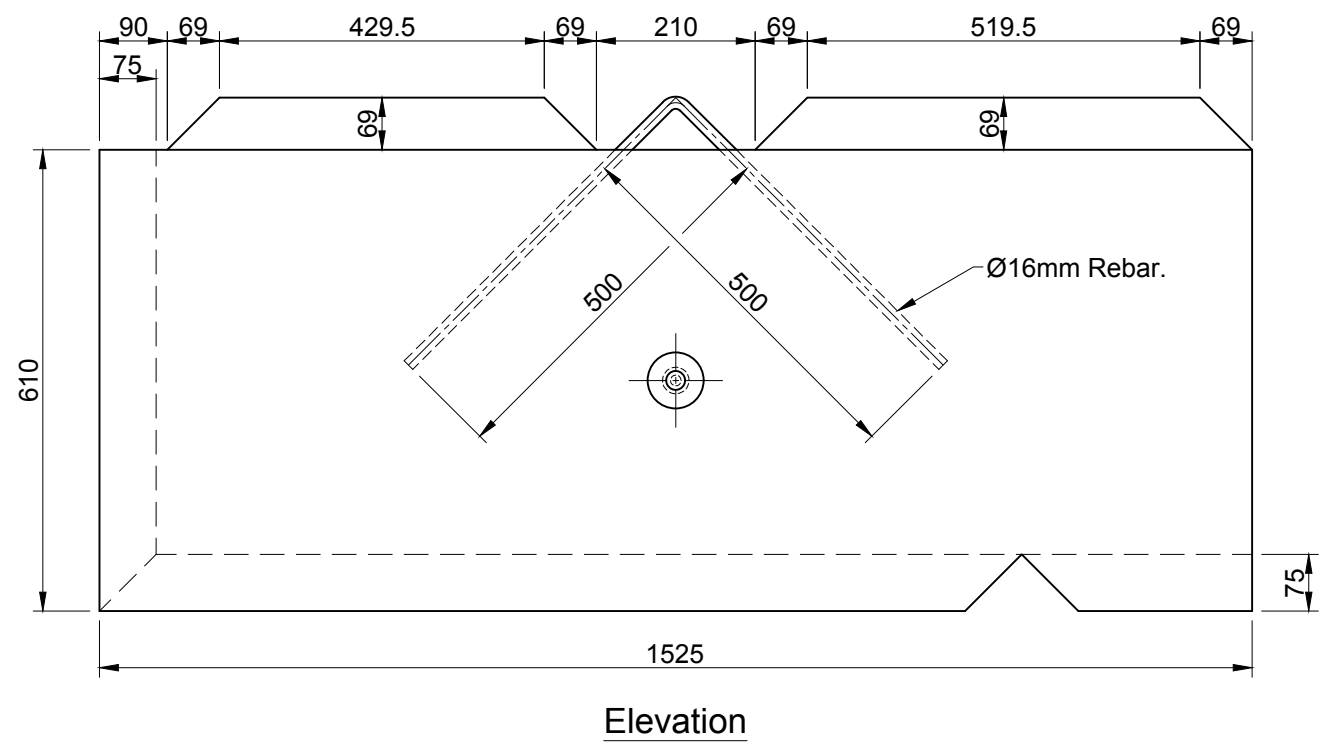
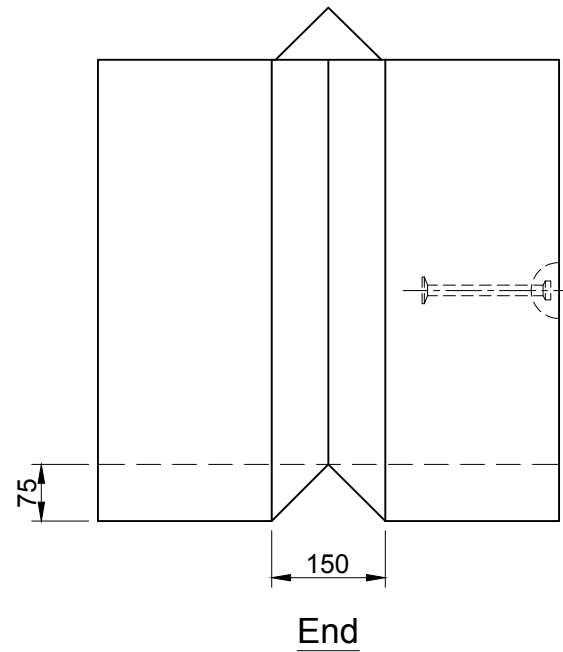

ALL Vee™ Interlocking Concrete Blocks are manufactured using high strength (50N/mm²) concrete and are Class A1 fire resistant in accordance with clause 4.3.4.4 of EN 13369.

										TITLE Vee™ Interlocking Concrete Block C2 - 1525 x 610 x 610 Elite Product Code : C2-1525				ELITE PRECAST CONCRETE LTD HALESFIELD 9, TELFORD SHROPSHIRE TF7 4QW											
REV	DATE	REASON FOR ISSUE	DRN	APP	REV	DATE	REASON FOR ISSUE	DRN	APP			DRN	CTC	CHKD	RMD	DATE	28-06-16	SIZE	A3	SCALE	1:10	DRG	EPC-VEE-022	REV	0
					0	28.06.16	For Information.			CTC	RMD														

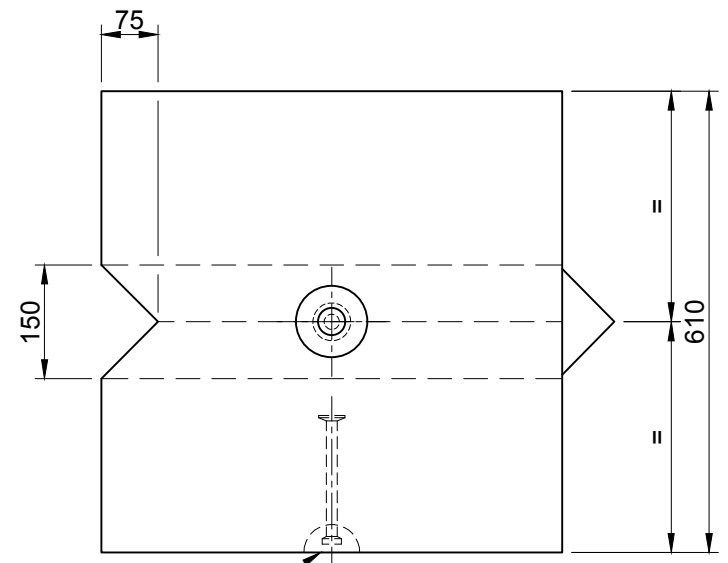

Ø74mm dia semi-spherical recess in gravitational centre of block for pin anchor.
(pin anchor is rated to 2.5 tonnes with a safety factor of 3).

Total Block Weight : 533Kg.

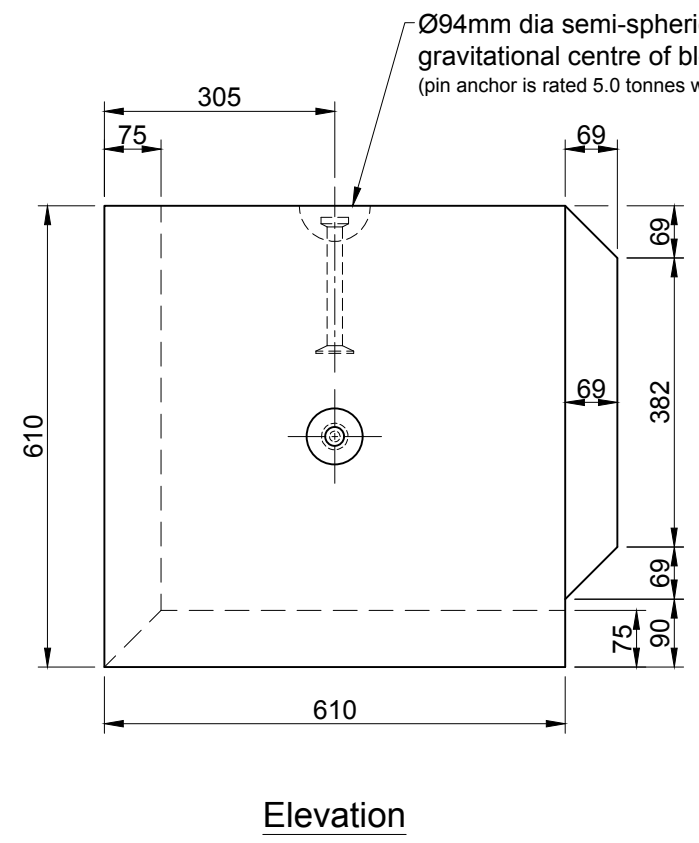
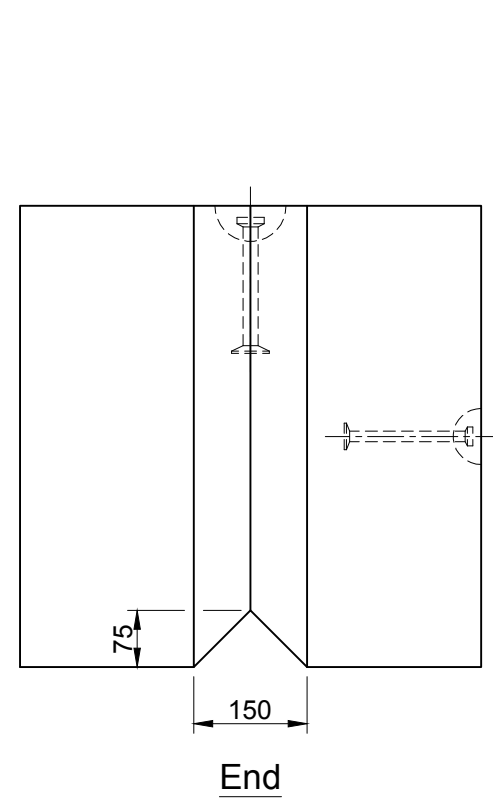

Ø94mm dia semi-spherical recess in gravitational centre of block for pin anchor.
(pin anchor is rated 5.0 tonnes with a safety factor of 3).

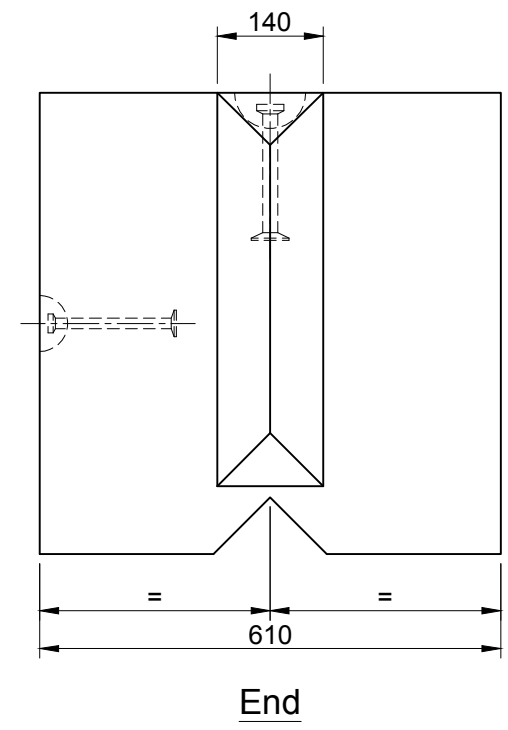

ALL Vee™ Interlocking Concrete Blocks are manufactured using high strength (50N/mm²) concrete and are Class A1 fire resistant in accordance with clause 4.3.4.4 of EN 13369.

										TITLE				ELITE PRECAST CONCRETE LTD HALESFIELD 9, TELFORD SHROPSHIRE TF7 4QW							
										Vee™ Interlocking Concrete Block FB - 610 x 610 x 610 Elite Product Code : FB-610				SIZE A3		SCALE 1:10				DRG EPC-VEE-015	
REV	DATE	REASON FOR ISSUE			DRN	APP	REV	DATE	REASON FOR ISSUE			DRN	APP	CTC	RMD	CHKD	RMD	DATE	28-06-16		
							O	28.06.16	For Information.			CTC	RMD								

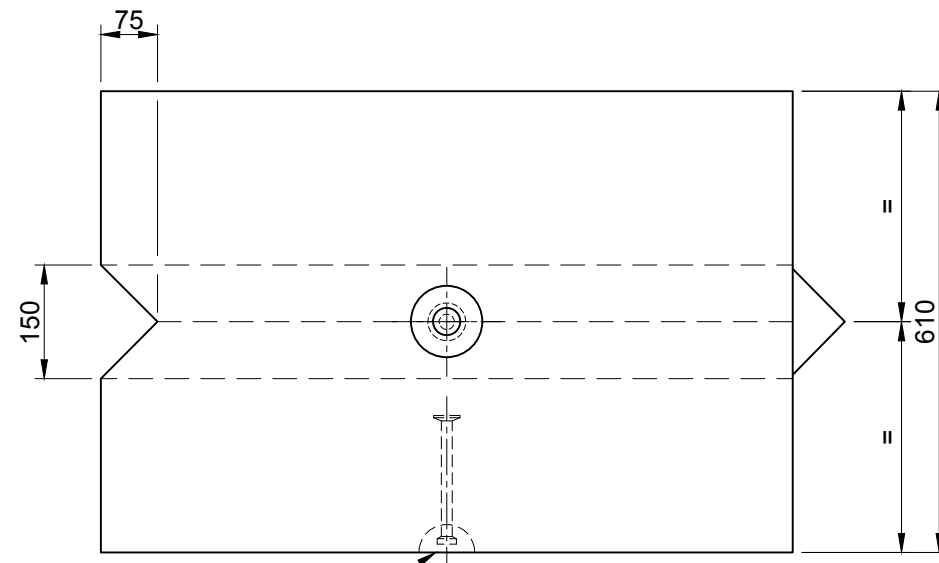

Ø74mm dia semi-spherical recess in gravitational centre of block for pin anchor.
(pin anchor is rated to 2.5 tonnes with a safety factor of 3).

Plan

Total Block Weight : 800Kg.

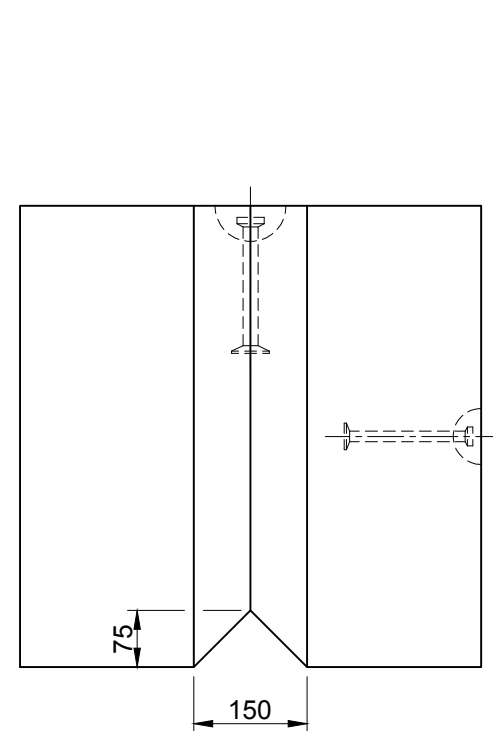

End

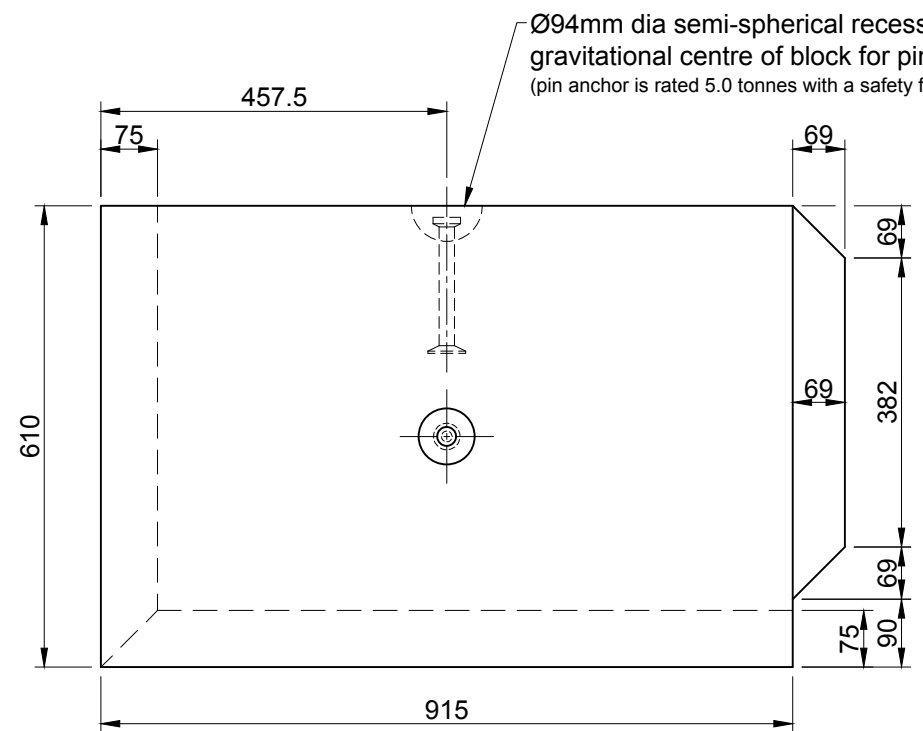

Elevation

Ø94mm dia semi-spherical recess in gravitational centre of block for pin anchor.
(pin anchor is rated 5.0 tonnes with a safety factor of 3).

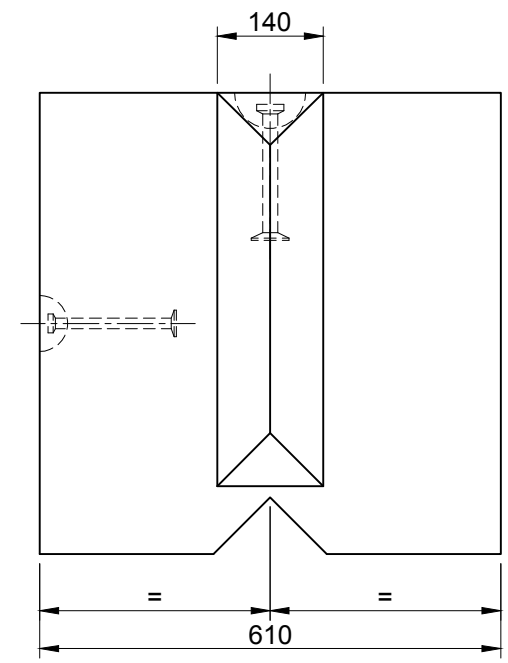

End

ALL Vee™ Interlocking Concrete Blocks are manufactured using high strength (50N/mm²) concrete and are Class A1 fire resistant in accordance with clause 4.3.4.4 of EN 13369.

										TITLE			ELITE PRECAST CONCRETE LTD HALESFIELD 9, TELFORD SHROPSHIRE TF7 4QW											
										Vee™ Interlocking Concrete Block FB - 915 x 610 x 610 Elite Product Code : FB-915														
REV	DATE	REASON FOR ISSUE	DRN	APP	REV	DATE	REASON FOR ISSUE	DRN	APP		DRN	CTC	CHKD	RMD	DATE	28-06-16	SIZE	A3	SCALE	1:10	DRG	EPC-VEE-014	REV	0
					0	28.06.16	For Information.					CTC		RMD										

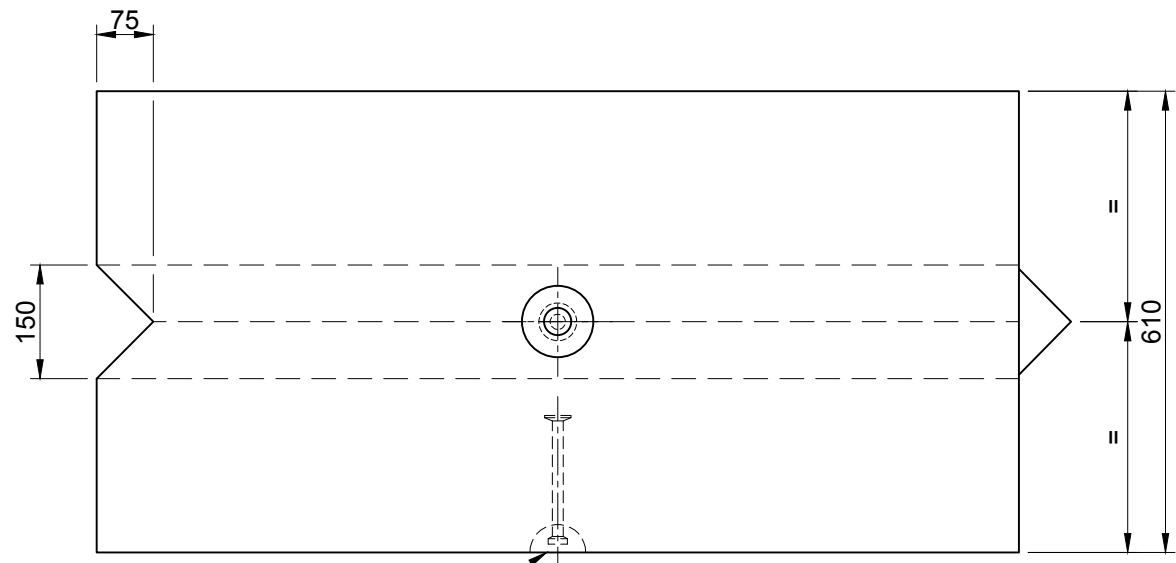

Ø74mm dia semi-spherical recess in gravitational centre of block for pin anchor.
(pin anchor is rated to 2.5 tonnes with a safety factor of 3).

Plan

Total Block Weight : 1067Kg.

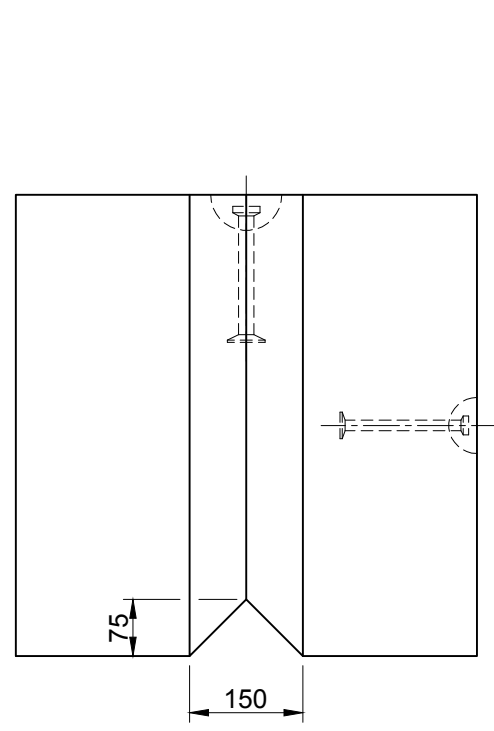

End

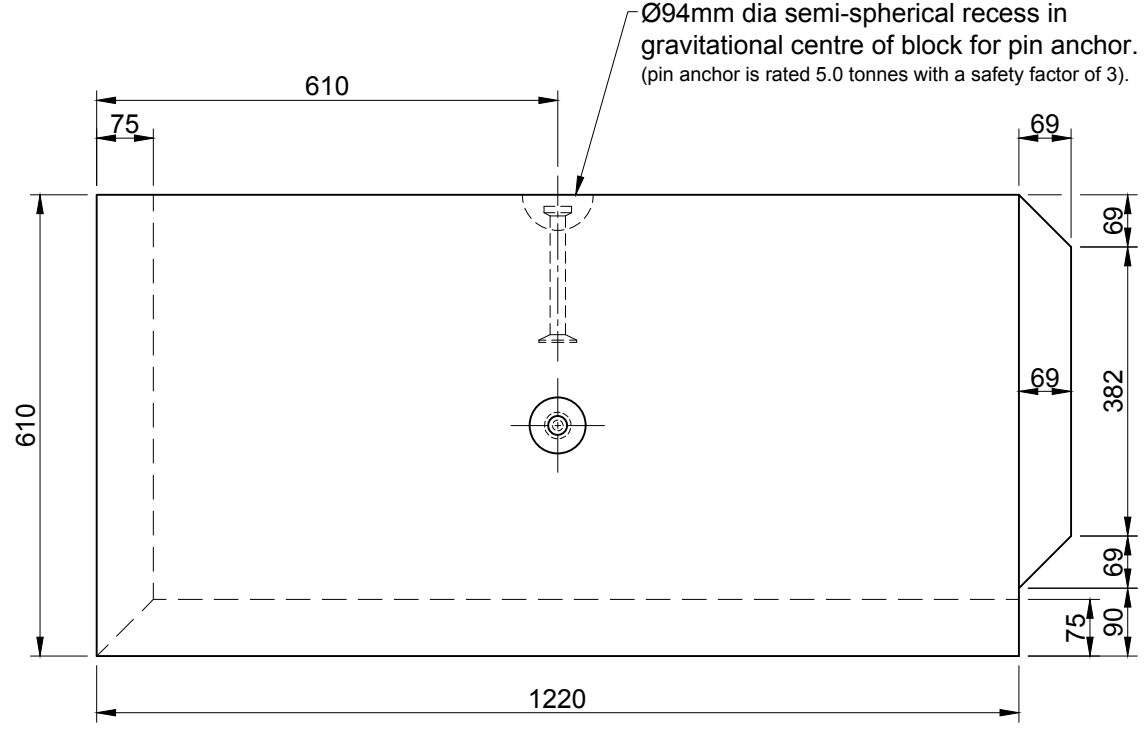

Elevation

Ø94mm dia semi-spherical recess in gravitational centre of block for pin anchor.
(pin anchor is rated 5.0 tonnes with a safety factor of 3).

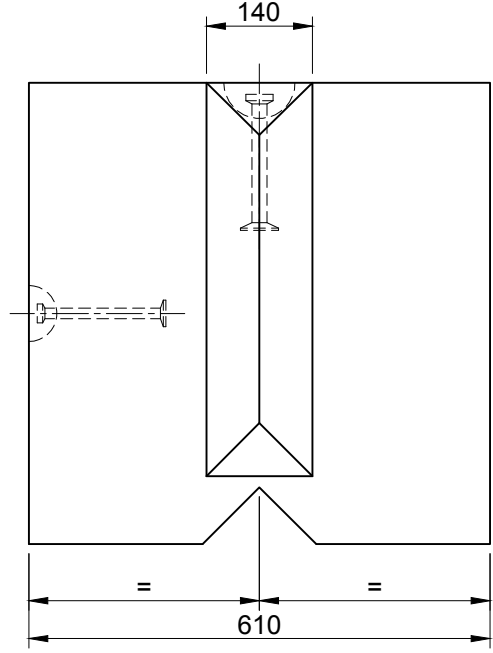

End

ALL Vee™ Interlocking Concrete Blocks are manufactured using high strength (50N/mm²) concrete and are Class A1 fire resistant in accordance with clause 4.3.4.4 of EN 13369.

										TITLE Vee™ Interlocking Concrete Block FB - 1220 x 610 x 610 Elite Product Code : FB-1220				ELITE PRECAST CONCRETE LTD HALESFIELD 9, TELFORD SHROPSHIRE TF7 4QW											
REV	DATE	REASON FOR ISSUE	DRN	APP	REV	DATE	REASON FOR ISSUE	DRN	APP	CTC	RMD	DRN	CTC	CHKD	RMD	DATE	28-06-16	SIZE	A3	SCALE	1:10	DRG	EPC-VEE-013	REV	0

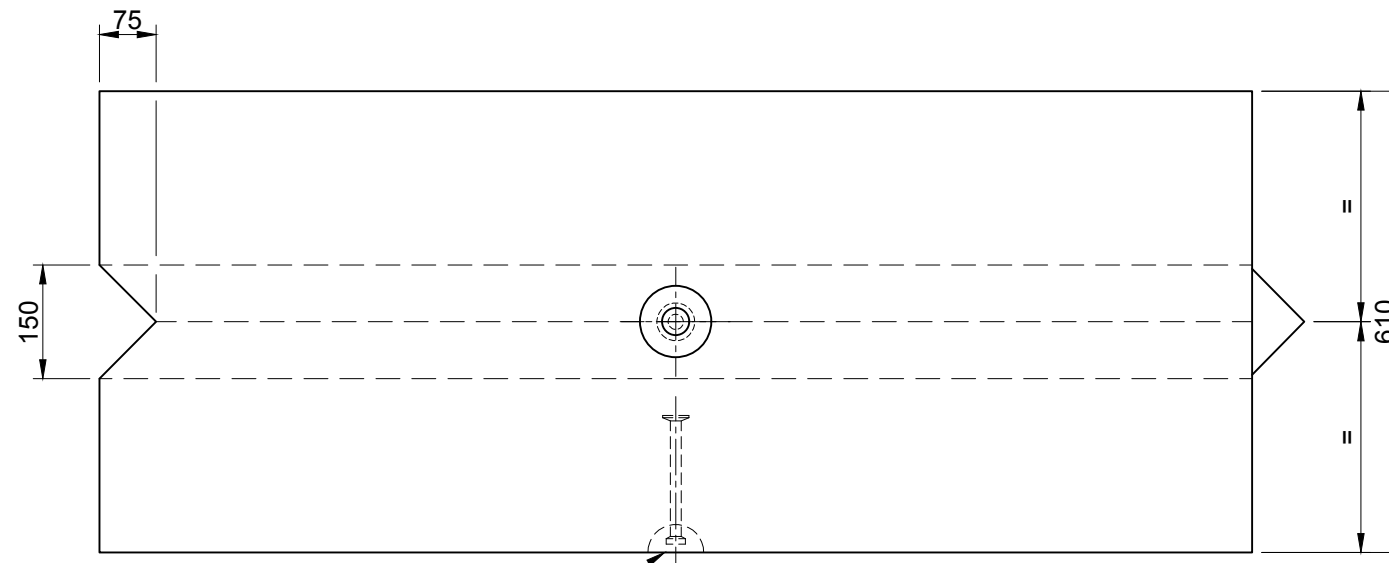

Ø74mm dia semi-spherical recess in gravitational centre of block for pin anchor.
(pin anchor is rated to 2.5 tonnes with a safety factor of 3).

Plan

Total Block Weight : 1333Kg.

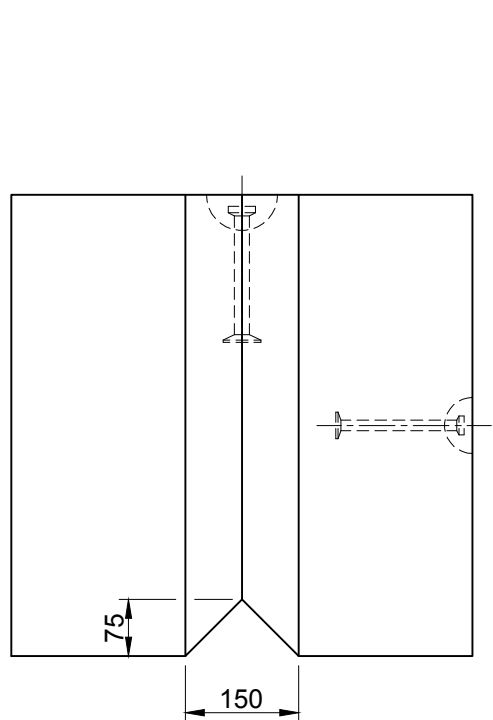

End

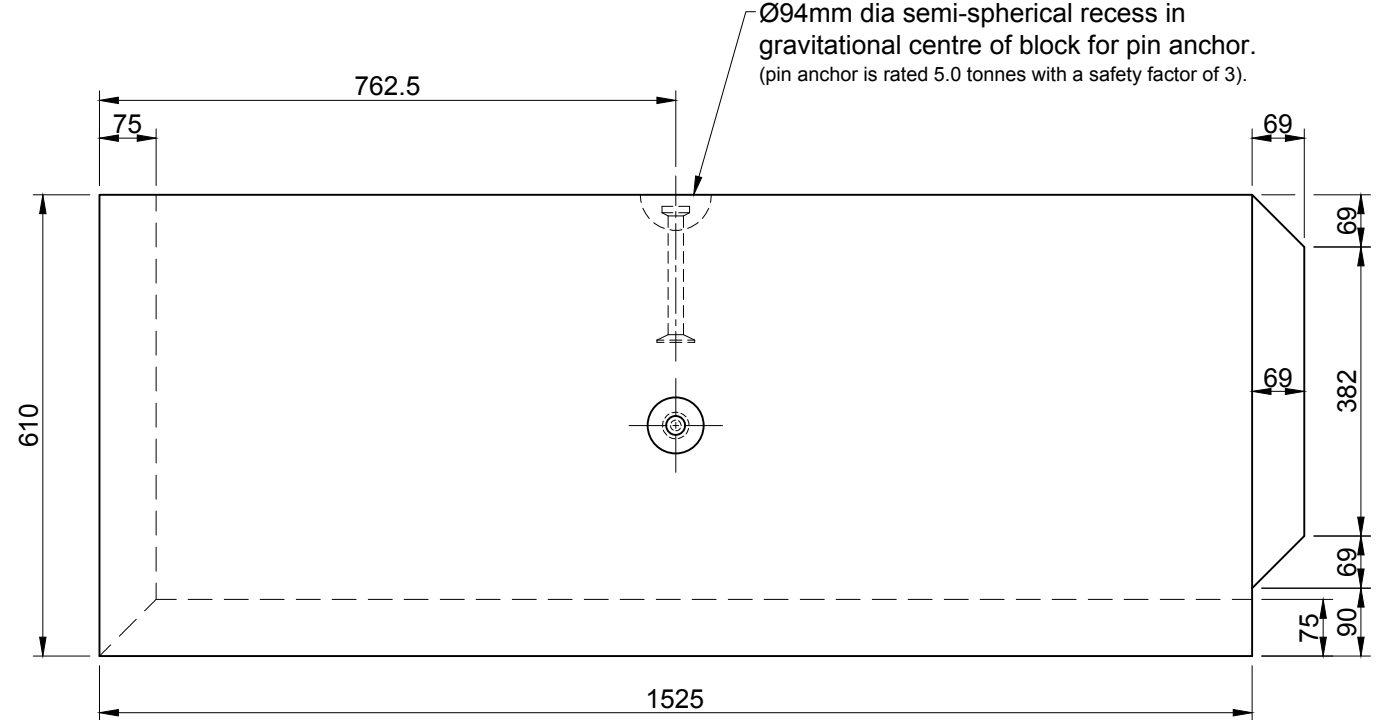

Elevation

Ø94mm dia semi-spherical recess in gravitational centre of block for pin anchor.
(pin anchor is rated 5.0 tonnes with a safety factor of 3).

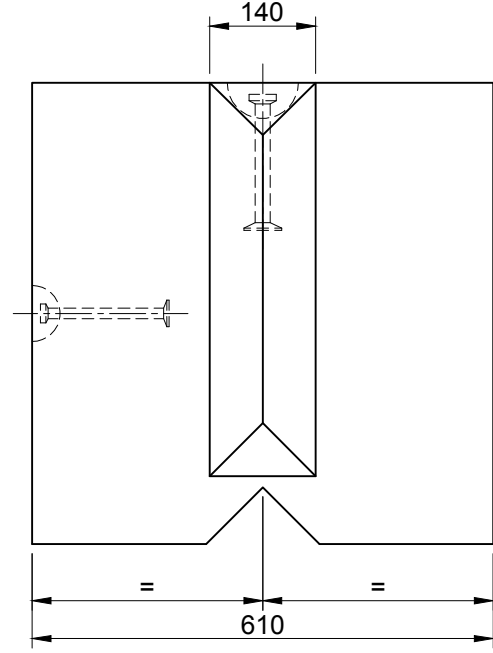

End

ALL Vee™ Interlocking Concrete Blocks are manufactured using high strength (50N/mm²) concrete and are Class A1 fire resistant in accordance with clause 4.3.4.4 of EN 13369.

										TITLE		Vee™ Interlocking Concrete Block FB - 1525 x 610 x 610 Elite Product Code : FB-1525		ELITE PRECAST CONCRETE LTD HALESFIELD 9, TELFORD SHROPSHIRE TF7 4QW											
REV	DATE	REASON FOR ISSUE	DRN	APP	REV	DATE	REASON FOR ISSUE	DRN	APP			DRN	CTC	CHKD	RMD	DATE	28-06-16	SIZE	A3	SCALE	1:10	DRG	EPC-VEE-012	REV	O
					O	28.06.16	For Information.																		

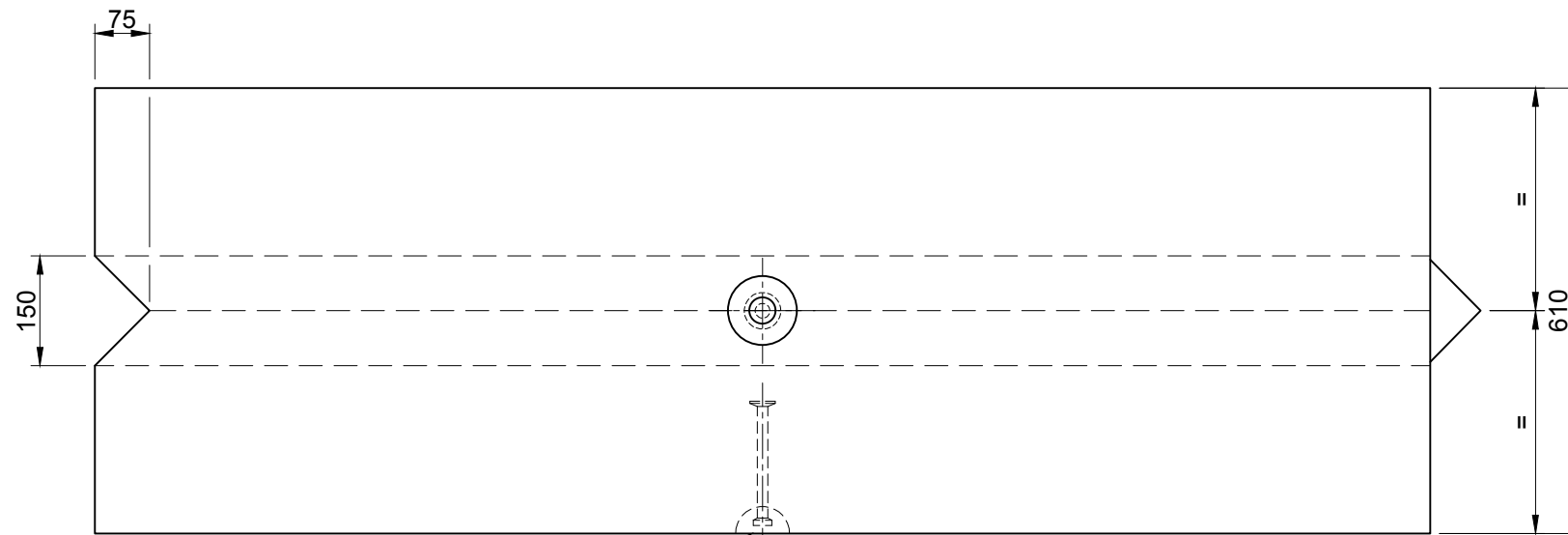

Ø74mm dia semi-spherical recess in gravitational centre of block for pin anchor.
(pin anchor is rated to 2.5 tonnes with a safety factor of 3).

Plan

Total Block Weight : 1600Kg.

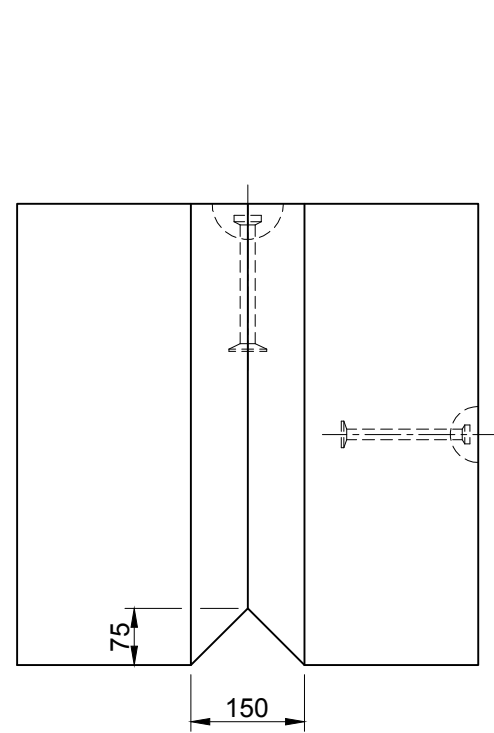

End

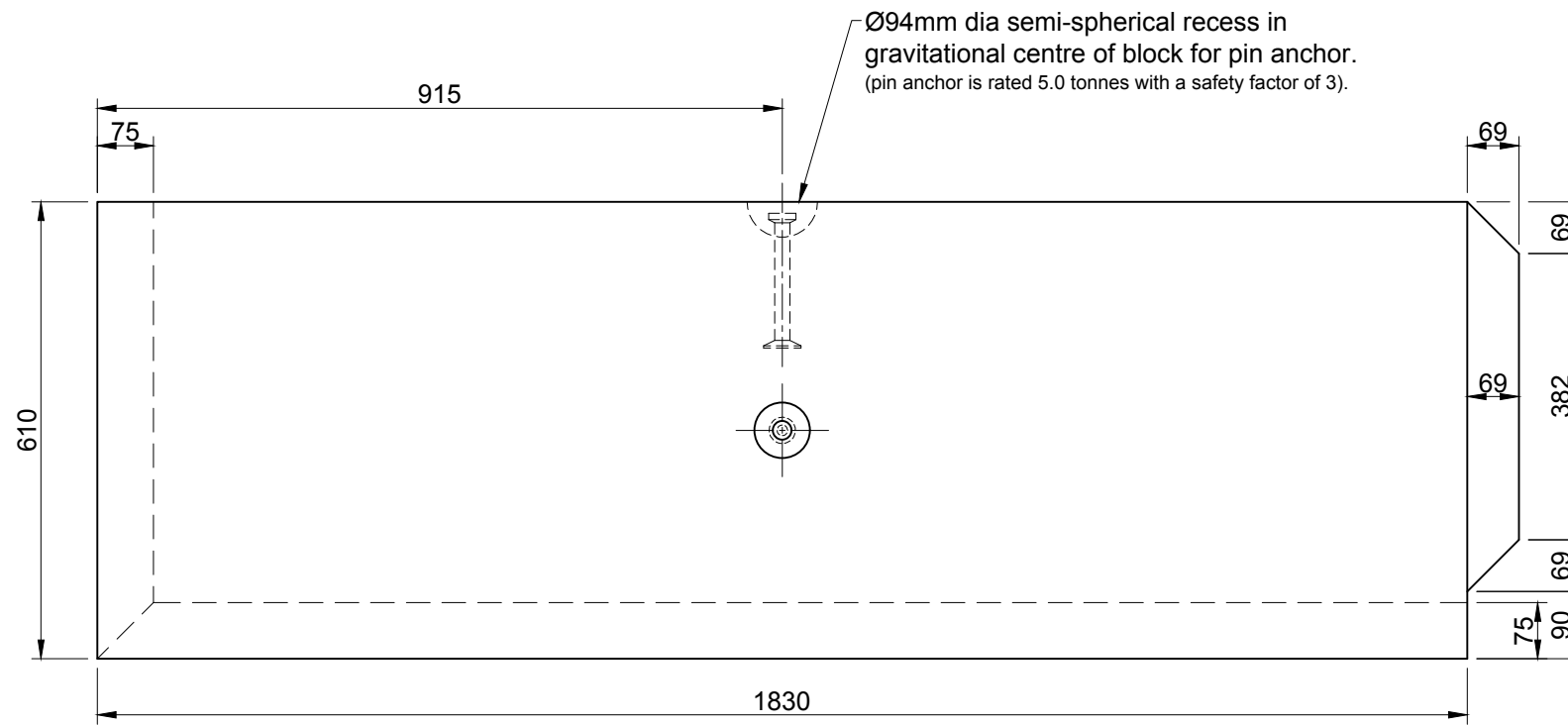

Elevation

Ø94mm dia semi-spherical recess in gravitational centre of block for pin anchor.
(pin anchor is rated 5.0 tonnes with a safety factor of 3).

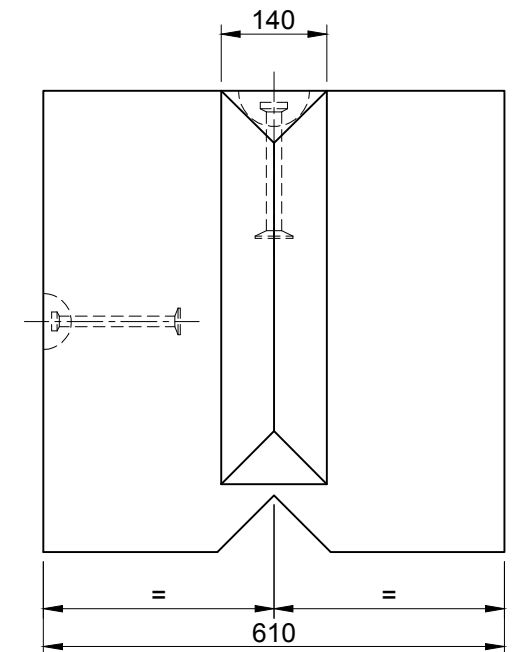

End

ALL Vee™ Interlocking Concrete Blocks are manufactured using high strength (50N/mm²) concrete and are Class A1 fire resistant in accordance with clause 4.3.4.4 of EN 13369.

REV	DATE	REASON FOR ISSUE	DRN	APP	REV	DATE	REASON FOR ISSUE	DRN	APP	TITLE	ELITE PRECAST CONCRETE LTD HALESFIELD 9, TELFORD SHROPSHIRE TF7 4QW	ELITE PRECAST CONCRETE	SIZE	SCALE	DRG	REV
					O	28.06.16	For Information.	CTC	RMD	Vee™ Interlocking Concrete Block FB - 1830 x 610 x 610 Elite Product Code : FB-1830			A3	1:10	EPC-VEE-011	O
										DRN CTC CHKD RMD DATE 28-06-16						

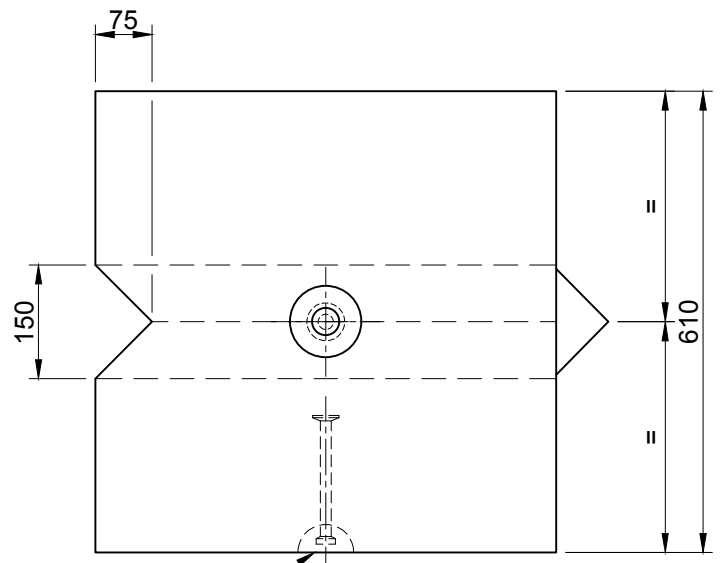

Plan

Ø74mm dia semi-spherical recess in gravitational centre of block for pin anchor. (pin anchor is rated to 2.5 tonnes with a safety factor of 3).

Total Block Weight : 266Kg.

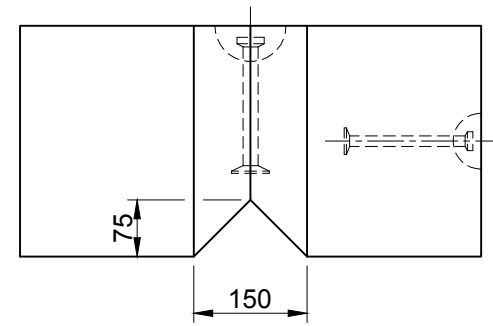

End

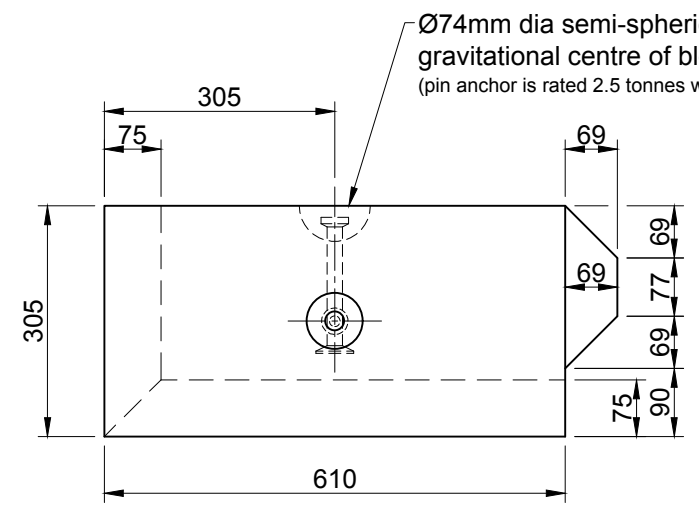

Elevation

Ø74mm dia semi-spherical recess in gravitational centre of block for pin anchor. (pin anchor is rated 2.5 tonnes with a safety factor of 3).

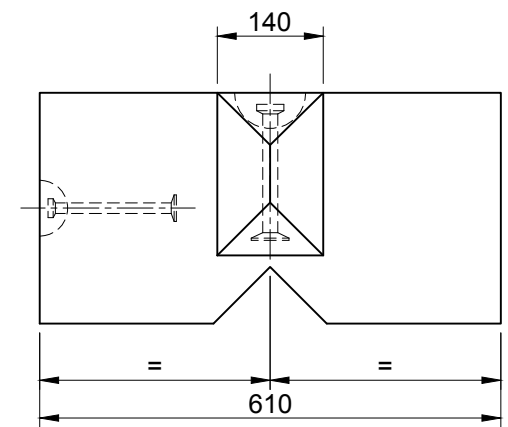

End

ALL Vee™ Interlocking Concrete Blocks are manufactured using high strength (50N/mm²) concrete and are Class A1 fire resistant in accordance with clause 4.3.4.4 of EN 13369.

										TITLE		ELITE PRECAST CONCRETE LTD HALESFIELD 9, TELFORD SHROPSHIRE TF7 4QW												
										Vee™ Interlocking Concrete Block HB - 610 x 610 x 305 Elite Product Code : HB-610														
REV	DATE	REASON FOR ISSUE	DRN	APP	REV	DATE	REASON FOR ISSUE	DRN	APP		DRN	CTC	CHKD	RMD	DATE	28-06-16	SIZE	A3	SCALE	1:10	DRG	EPC-VEE-020	REV	0
					0	28.06.16	For Information.																	

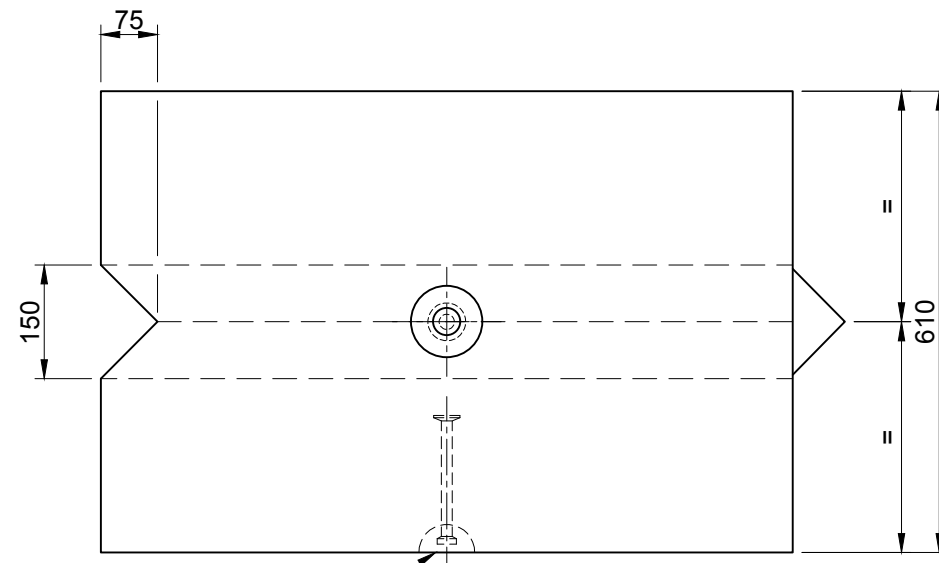

Ø74mm dia semi-spherical recess in gravitational centre of block for pin anchor.
(pin anchor is rated to 2.5 tonnes with a safety factor of 3).

Plan

Total Block Weight : 400Kg.

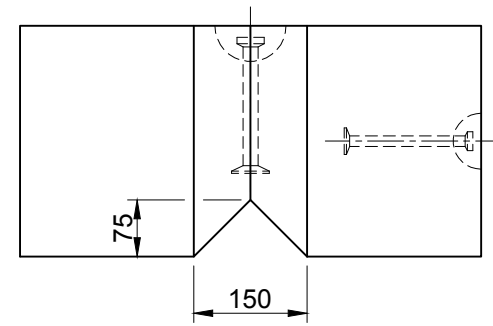

End

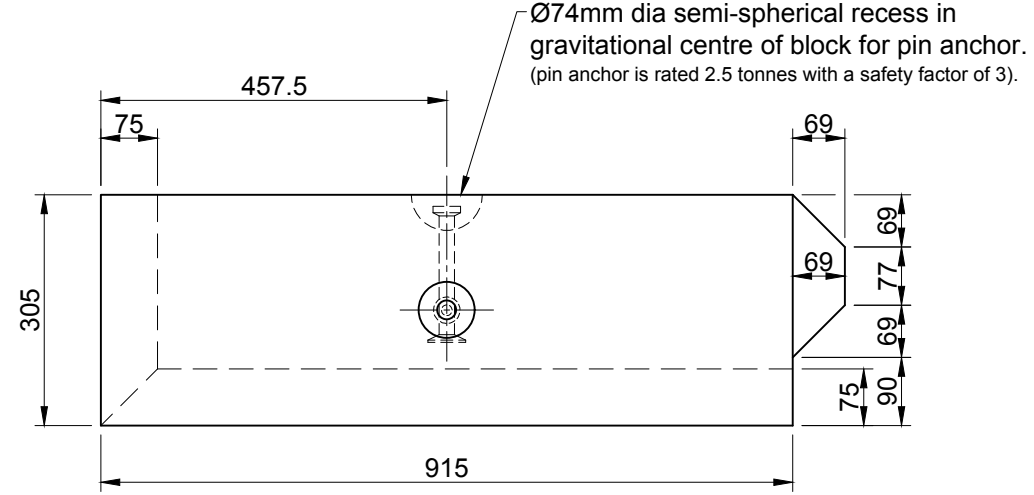

Elevation

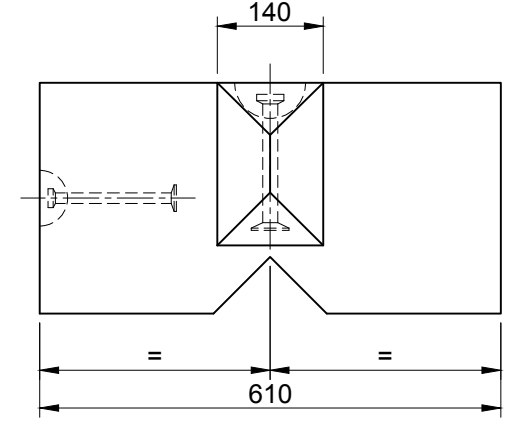

End

ALL Vee™ Interlocking Concrete Blocks are manufactured using high strength (50N/mm²) concrete and are Class A1 fire resistant in accordance with clause 4.3.4.4 of EN 13369.

										TITLE				ELITE PRECAST CONCRETE LTD HALESFIELD 9, TELFORD SHROPSHIRE TF7 4QW											
										Vee™ Interlocking Concrete Block HB - 915 x 610 x 305 Elite Product Code : HB-915															
REV	DATE	REASON FOR ISSUE	DRN	APP	REV	DATE	REASON FOR ISSUE	DRN	APP			DRN	CTC	CHKD	RMD	DATE	28-06-16	SIZE	A3	SCALE	1:10	DRG	EPC-VEE-019	REV	0
					0	28.06.16	For Information.																		

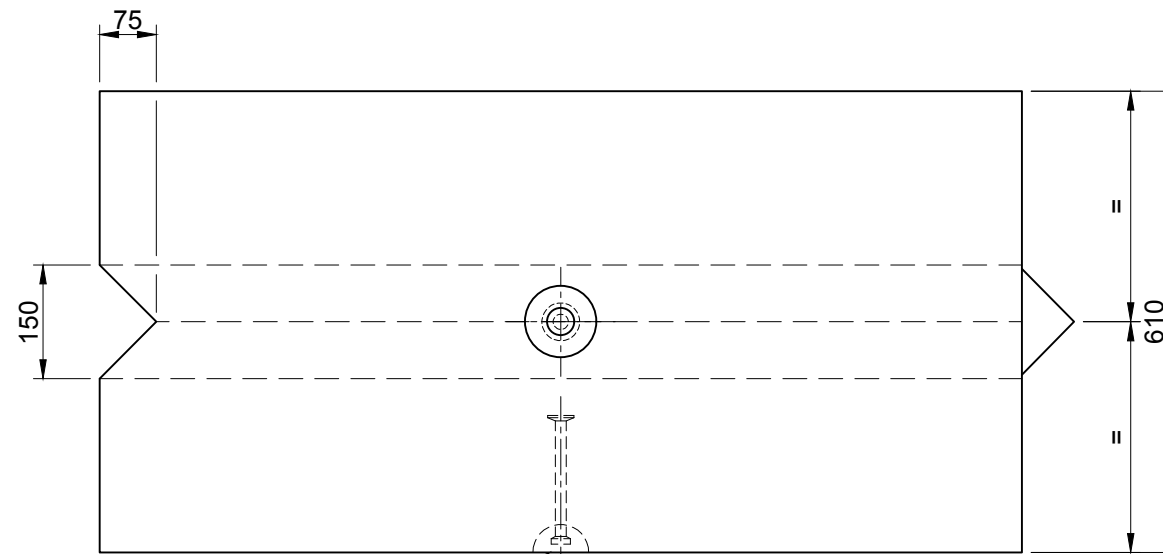

Ø74mm dia semi-spherical recess in gravitational centre of block for pin anchor.
(pin anchor is rated to 2.5 tonnes with a safety factor of 3).

Plan

Total Block Weight : 533Kg.

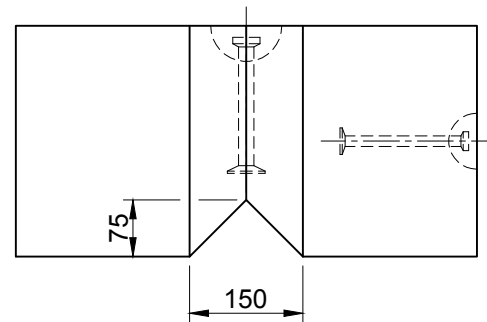

End

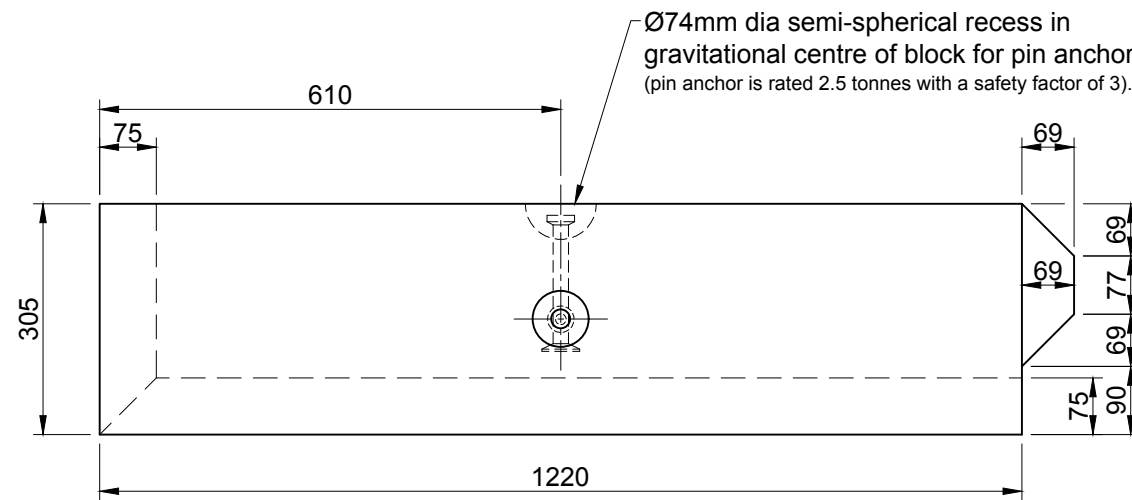

Elevation

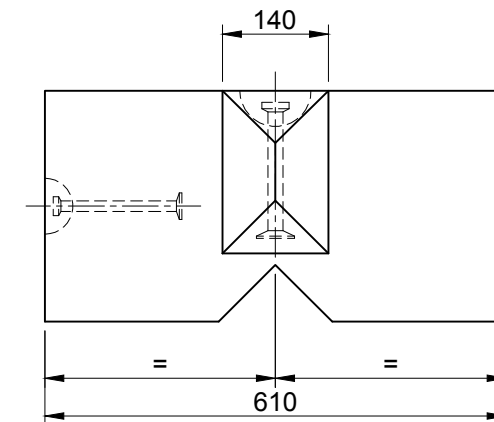

End

ALL Vee™ Interlocking Concrete Blocks are manufactured using high strength (50N/mm²) concrete and are Class A1 fire resistant in accordance with clause 4.3.4.4 of EN 13369.

										TITLE				ELITE PRECAST CONCRETE LTD HALESFIELD 9, TELFORD SHROPSHIRE TF7 4QW					
										Vee™ Interlocking Concrete Block HB - 1220 x 610 x 305 Elite Product Code : HB-1220				SIZE A3		SCALE 1:10			
REV	DATE	REASON FOR ISSUE	DRN	APP	REV	DATE	REASON FOR ISSUE	DRN	APP			DRN	CTC	CHKD	RMD	DATE	28-06-16	REV	○
					○	28.06.16	For Information.			CTC	RMD								

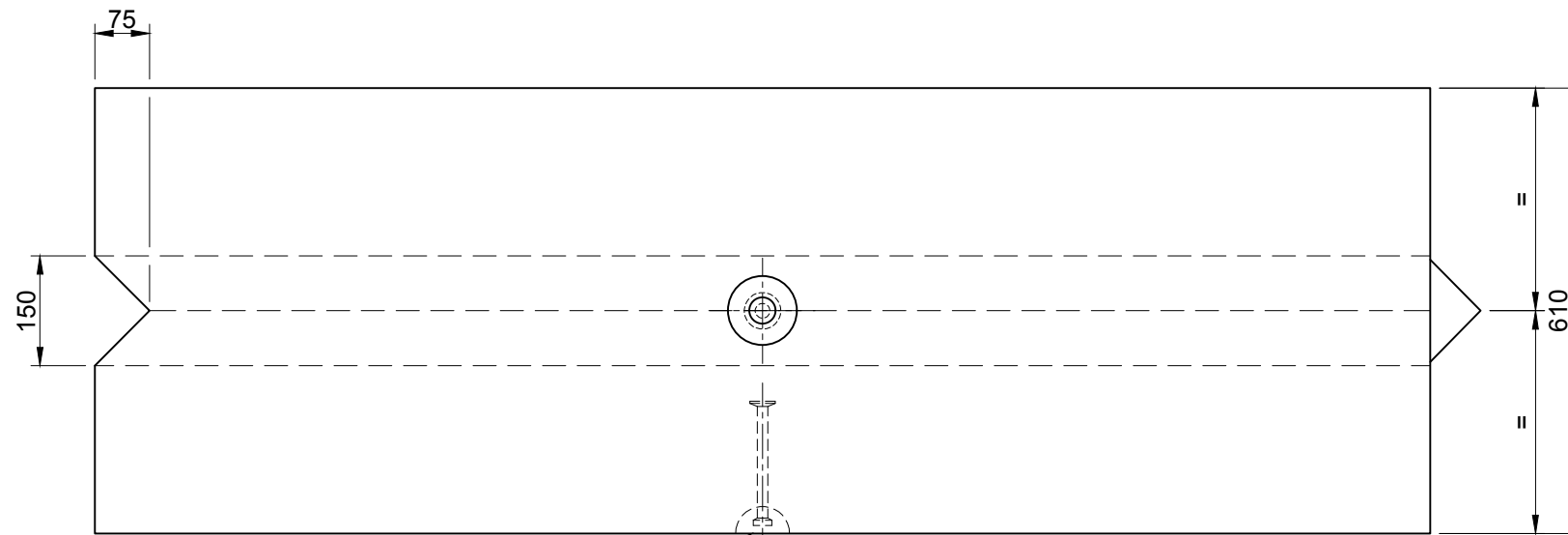

Ø74mm dia semi-spherical recess in gravitational centre of block for pin anchor.
(pin anchor is rated to 2.5 tonnes with a safety factor of 3).

Plan

Total Block Weight : 800Kg.

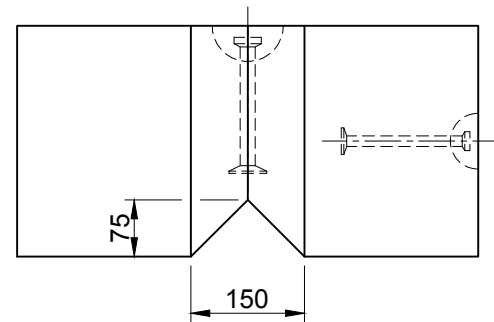

End

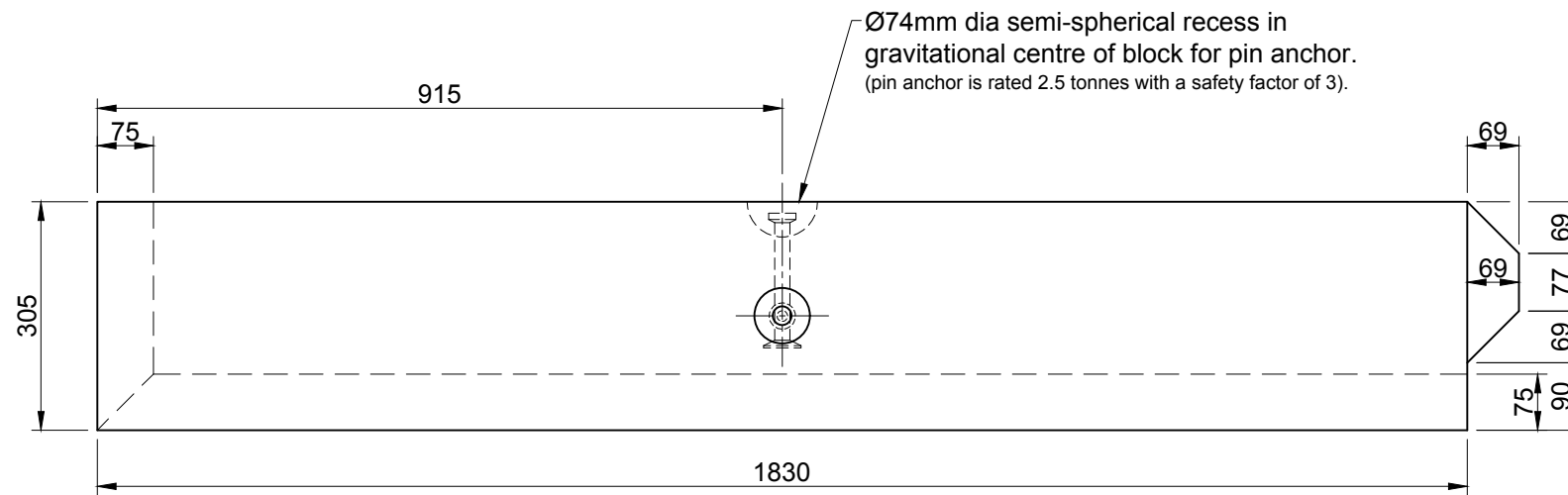

Elevation

Ø74mm dia semi-spherical recess in gravitational centre of block for pin anchor.
(pin anchor is rated 2.5 tonnes with a safety factor of 3).

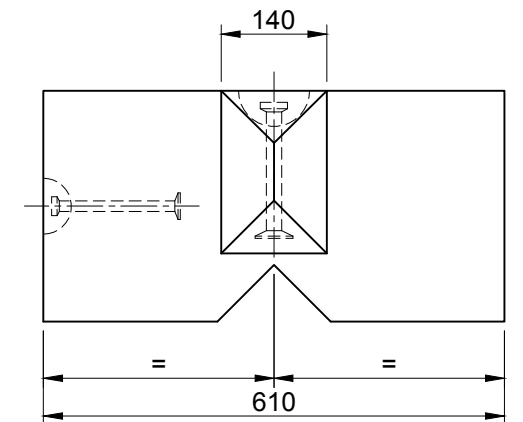

End

ALL Vee™ Interlocking Concrete Blocks are manufactured using high strength (50N/mm²) concrete and are Class A1 fire resistant in accordance with clause 4.3.4.4 of EN 13369.

										TITLE		ELITE PRECAST CONCRETE LTD HALESFIELD 9, TELFORD SHROPSHIRE TF7 4QW													
										Vee™ Interlocking Concrete Block HB - 1830 x 610 x 305 Elite Product Code : HB-1830															
REV	DATE	REASON FOR ISSUE	DRN	APP	REV	DATE	REASON FOR ISSUE	DRN	APP			DRN	CTC	CHKD	RMD	DATE	28-06-16	SIZE	A3	SCALE	1:10	DRG	EPC-VEE-016	REV	0

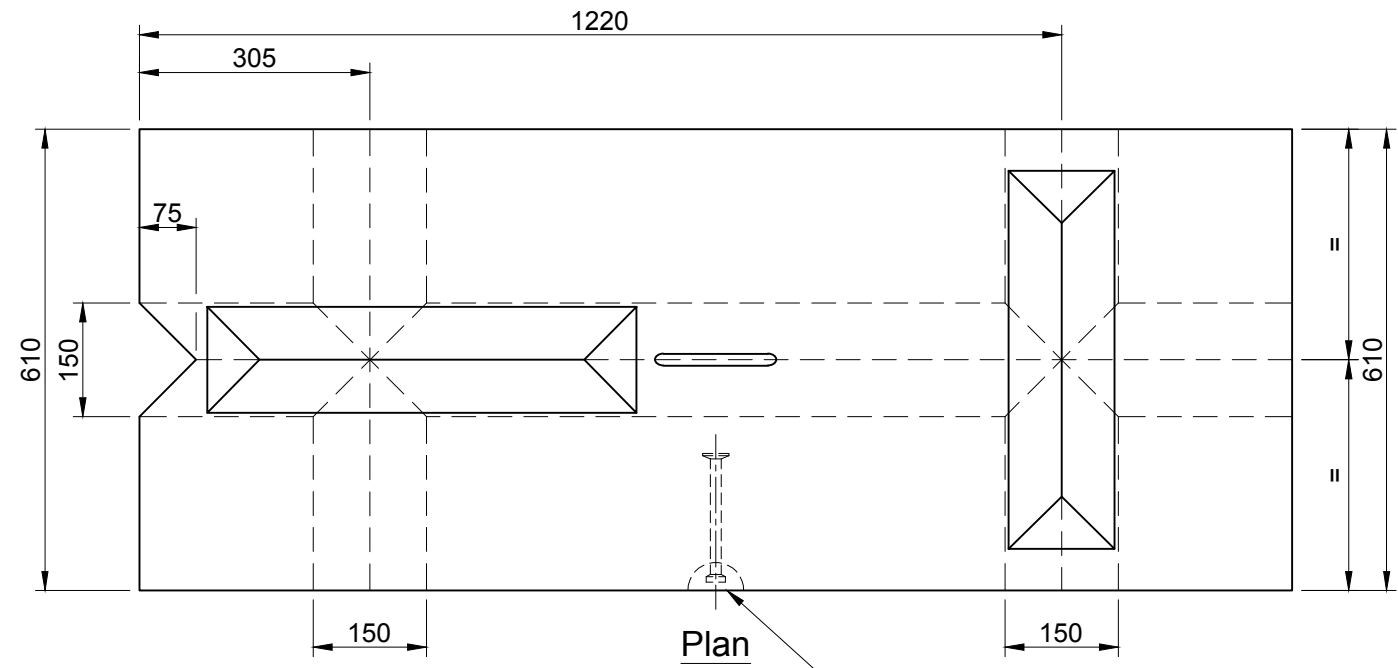

Total Block Weight : 1333Kg.

Ø74mm dia semi-spherical recess in gravitational centre of block for pin anchor. (pin anchor is rated to 2.5 tonnes with a safety factor of 3).

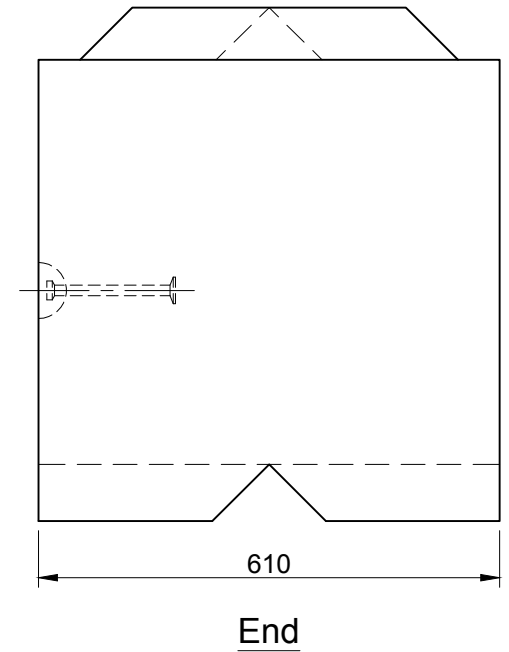
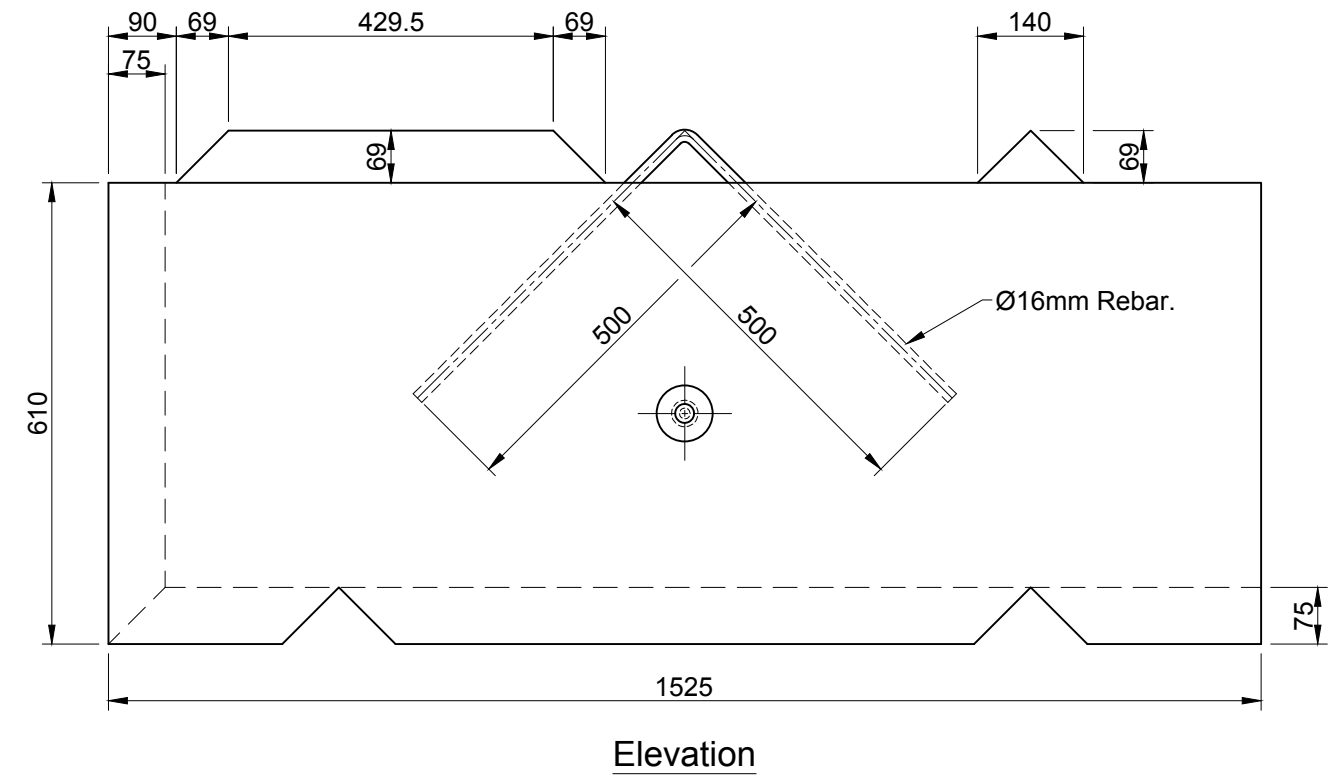
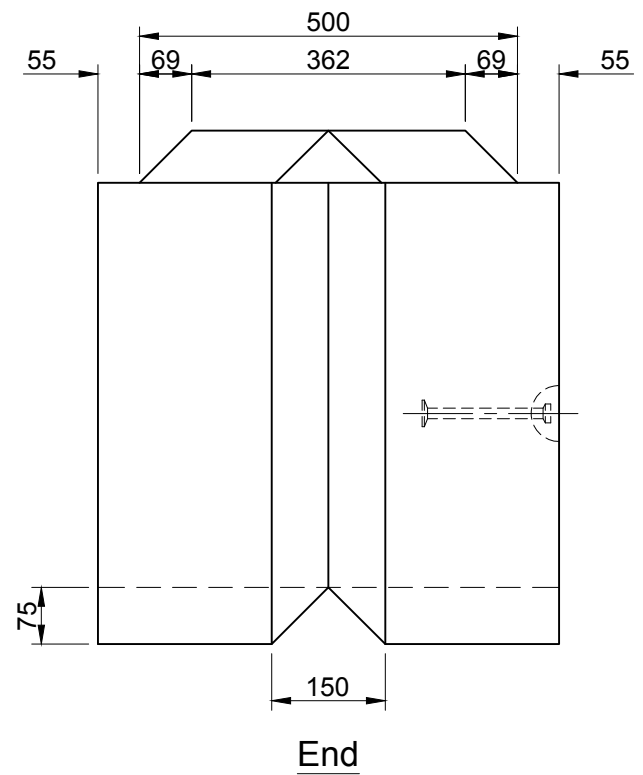

ALL Vee™ Interlocking Concrete Blocks are manufactured using high strength (50N/mm²) concrete and are Class A1 fire resistant in accordance with clause 4.3.4.4 of EN 13369.

										TITLE		Vee™ Interlocking Concrete Block T2 - 1525 x 610 x 610 Elite Product Code : C2-1525		ELITE PRECAST CONCRETE LTD HALESFIELD 9, TELFORD SHROPSHIRE TF7 4QW											
REV	DATE	REASON FOR ISSUE	DRN	APP	REV	DATE	REASON FOR ISSUE	DRN	APP	CTC	RMD	DRN	CTC	CHKD	RMD	DATE	28-06-16	SIZE	A3	SCALE	1:10	DRG	EPC-VEE-023	REV	0

PROJECTION

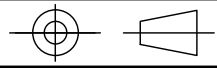

Total Capping Stone Weight : 790Kg

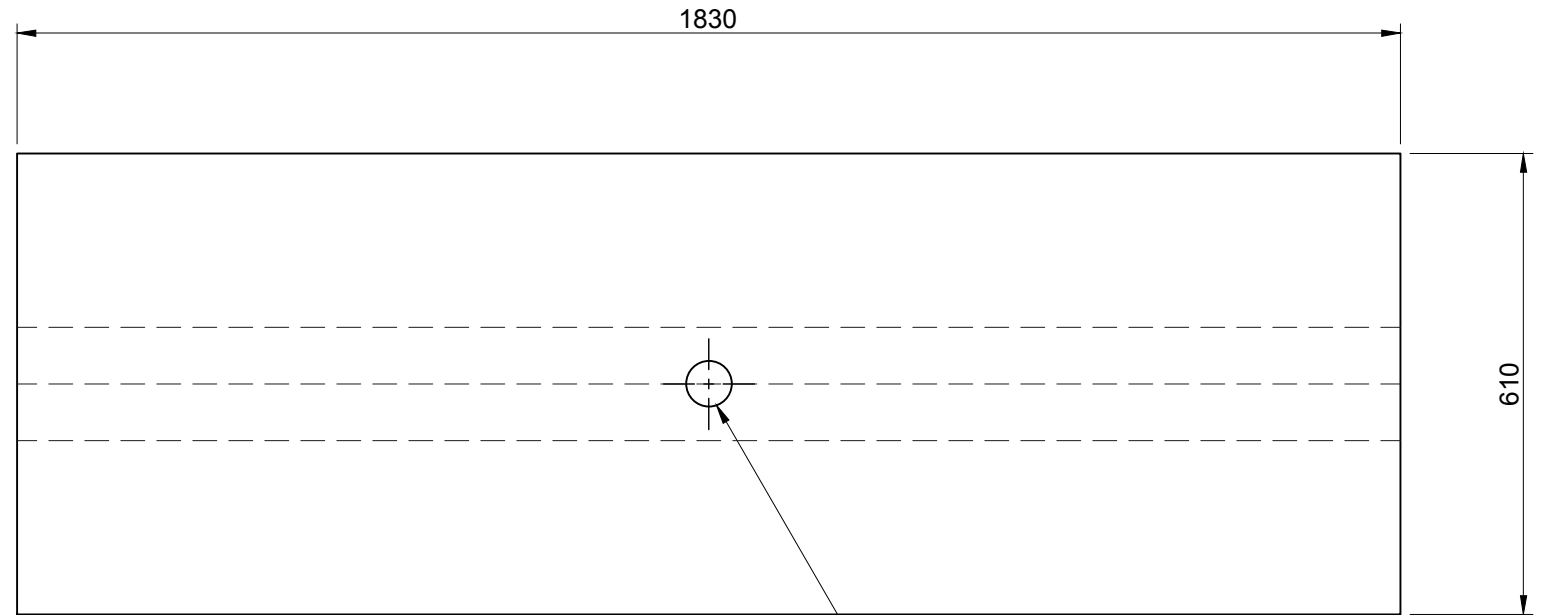
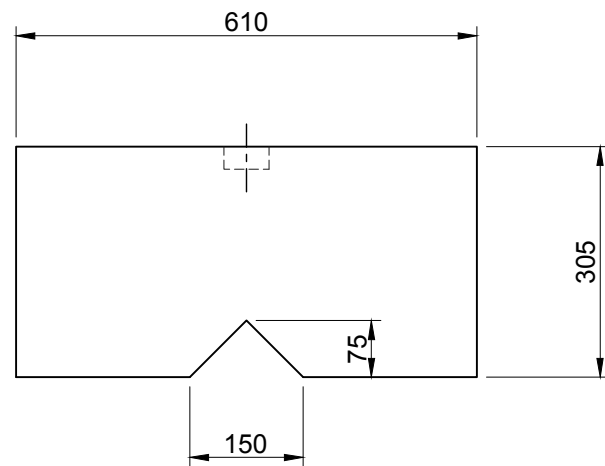

Ø60mm Dia Semi-Spherical Recess in Gravitational Centre of Block for 'Deha' type Lifting Pin.
(Lifting Pin is rated to 2.5 tonnes with a safety factor of 3).

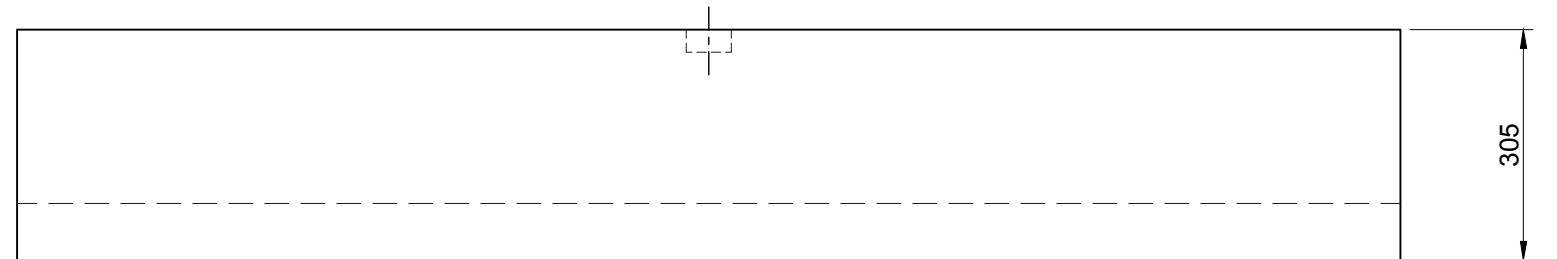

REV	DATE	REASON FOR ISSUE	DRN	APP	REV	DATE	REASON FOR ISSUE	DRN	APP
					O	31.10.13	For Information		
								CTC	RD

TITLE : Vee™ Interlock Block Capping Stone x 1830mm Long Elite Product Code : Capping Stone			ELITE PRECAST CONCRETE LIMITED HALESFIELD 9, TELFORD SHROPSHIRE TF7 4QW										
DRN :	CTC	CHKD :	RD	DATE :	31-10-13	DRG SIZE :	A3	SCALE :	1:10	DRG	062	REV	O