

UNTHA

shredding technology

The reliable brand!

RS

Compact machines
with big recycling capabilities



RS30, RS40



WELCOME TO UNTHA UK – YOUR SHREDDING PARTNER

If you're looking for an experienced shredding specialist that can supply world-class technology, configured to suit the exact requirements of your waste management/recycling operations, you've come to the right place.

BUT THERE'S MORE TO UNTHA THAN MACHINERY.

The level of knowledge and expertise that goes in to researching, designing and engineering our state-of-the-art shredders is also mirrored in the customer support services that we provide. That means we're not just a machinery vendor. We're also a friendly, forward-thinking and hard-working team of waste experts committed to becoming your shredding partner long after the sale.

WE OFFER:

- > Shredder trials
- > Operator training
- > Service and maintenance packages
- > Spare and wear parts
- > Finance
- > Complete systems solutions

The list goes on, but ultimately, your long-term satisfaction is our priority.

UNTHA UK – Your reliable shredding partner

INTRODUCING THE RS30 & RS40

The RS30 and RS40 shredders may be compact, but they've been proven to excel in some of the most demanding environments in the recycling industry.

Like the larger shredders within the RS series, these powerful little machines contain robust four shaft technology that achieve exacting output specifications and impressive throughputs. Hard-wearing cutters and integrated protection from unshreddables equate to unrivalled uptime and low wear. And maintenance is quick and easy for maximum availability.

This shredding solution is built to be configured to your specific recycling requirements, which all translates into an attractive investment guaranteed to boost your profitability.

Talk to us about what is possible...

WASTE & RECYCLING APPLICATIONS:

- > Hard drives
- > Mobile phones
- > Smaller WEEE appliances
- > Confidential waste
- > Secure product destruction
- > Metal chips
- > Packaging & production waste
- > And more...

**DID YOU
KNOW... ?**

You can trial this
shredder using your
own materials.
Enquire today!

QUALITY FEATURES

High availability

- > integrated electronic shut-down for unshreddable items
- > resistant to foreign material due to low speed cutting shafts
- > integrated central lubrication system (A)
- > maintenance-free mechanical seals (B) prevent dirt and dust from entering into gears and bearings
- > electric oil level monitoring
- > easily replaceable wear plates (C)
- > straight forward design (no hydraulics, couplings, etc.) ensures reliable operation
- > cutting disks with integral collar (no separate spacers) distributes cutting force over wide area

Operational advantages

- > quick change screen system (E)
- > Reliable drive with two independent motors and robust spur gear (F)
- > unique anti jam screen design (G) with bevelled sides
- > consistent final particle size
- > one step pre- and re-shredding
- > self feeding for most materials – no ram required
- > low noise and dust generation

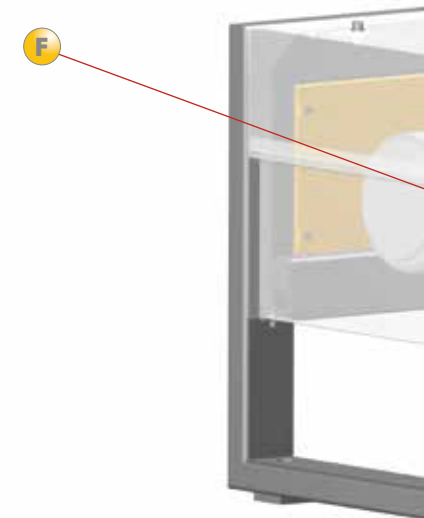
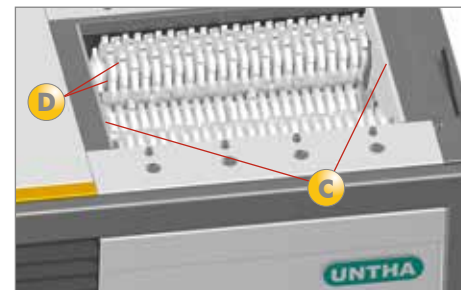
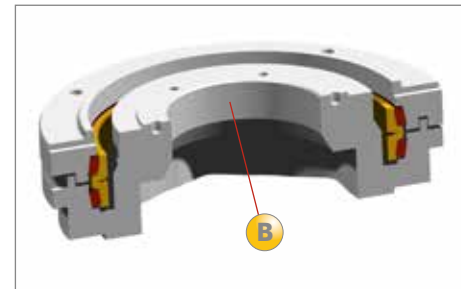



Functional design

- > operational controls **H** directly at the machine with integrated emergency stop
- > new enclosure design protects all components from dirt and dust
- > sectional tubular steel frame **I** resists warping
- > compact design integrates into complex installations without difficulty
- > universal discharge flange easily interfaces with downstream components
- > can be loaded from all sides

Unique productive

- > very large screen area ensures high throughput
- > high torque drive easily handles tough materials
- > standard cutting chamber wear plates

Low noise and dust pollution

- > low-speed cutting shafts





OUR FACILITIES:

When you invest in an UNTHA shredder, you don't just receive a piece of machinery. You also have access to a range of facilities at our North Yorkshire headquarters, including:

- > **OUR 'TEST CENTRE'**, which allows you to trial our equipment and conduct feasibility studies using your own materials.
- > **ON-SITE TRAINING COURSES**, developed specifically for our shredders and held away from your premises (if you wish), to ensure your staff are rigorously equipped with the skills they need to efficiently run, maintain and optimise your machine.
- > **VIP INVITATIONS TO OUR PROGRAMME OF CONFERENCES**, with guest seminars and learning sessions delivered by notable industry figures.





CUSTOMER SUPPORT SERVICES:

Your shredder is an asset engineered to deliver a return on investment long into the future. That's why we're as renowned for our customer support services, as we are our technology. These services include:

- > **PREVENTATIVE MAINTENANCE PLANS** and **SERVICING REGIMES** tailored to your application.
- > **CUTTER** (and **SCREEN**) plus complete machine overhauls.
- > The **SUPPLY OF HIGH QUALITY, READILY-AVAILABLE** spare and wear parts.
- > An **ENGINEERING HELPLINE** with remote diagnostics, if you encounter any issues or want to optimise the performance of your shredder.

Want to avoid fluctuating after sales costs? Talk to us about devising an affordable plan – and one consistent payment – to suit your needs.



BUYING AN UNTHA SHREDDER

Our shredders have been specifically designed with value and return on investment in mind. But our commitment to saving you money doesn't stop there. We also offer a range of flexible procurement options to suit the requirements of YOUR business.

PURCHASE OUTRIGHT

If you have the capital available to purchase the machine outright we will prepare a comprehensive quote inclusive of the shredding technology itself and the commissioning project. We can also factor in a customer support package tailored to your operational needs, so that you can benefit from the expertise and assistance of our dedicated after sales team long after the initial installation.

FINANCE AVAILABLE

If you would prefer to spread the cost of the investment, we work with some of the UK's leading finance partners for every level of shredding project. That means one manageable, all-inclusive monthly payment for a term to suit you, with no hidden costs or unexpected surprises.

With knowledge of all the latest grants available, our finance partners can also advise how you can access funding to make your investment even more affordable.

Talk to us about your budget and preferred procurement method and we'll tailor our proposal accordingly.

RS Series

4-shaft shredding system

| TECHNICAL DATA | | RS30 | RS40 |
|------------------------|-----|-------------|-------------------|
| Power | kW | 11/15/22 | 30/37/44 |
| Cutting chamber | mm | 450 x 600 | 750/1000 x 700 |
| No. of cutting shafts | | 4 | 4 |
| Speed main shafts | rpm | 23 | 24 |
| Speed secondary shafts | rpm | 34 | 32 |
| Perforated screen Ø | mm | 15 - 40 | 15 - 40 |
| Weight | kg | appr. 2,000 | appr. 3,300/3,600 |

All dimensions in mm.

40 years of expertise.
More than 9,000 shredders in daily operation!

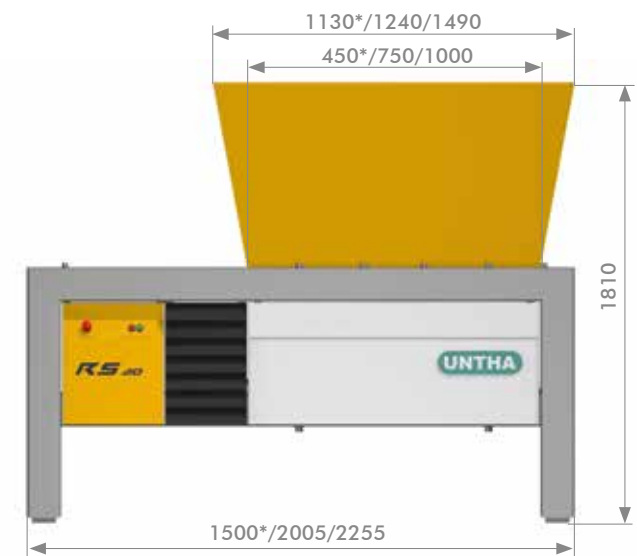
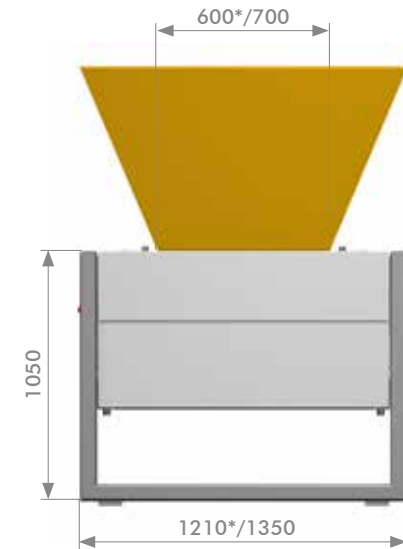



UNTHA

shredding technology

The reliable brand!



UNTHA shredding technology

Kellau 141
A-5431 Kuchl / Salzburg, Austria
Tel +43 6244 7016 0
Fax +43 6244 7016 1
info@untha.com
www.untha.com

UNTHA UK LTD

Excel House, Becklands Close,
Bar Lane, Roecliffe, Boroughbridge
YO51 9NR York
United Kingdom
Phone +44 845 450 5388
Fax +44 845 450 5389
sales@untha.co.uk
www.untha.co.uk

